



Prepared For  
**Apollo Customers**  
 Attn: All Users  
 U.S.A.

Capacity Table For  
**GFR-04 Series Gas Filter**  
 (\*\*\*)

Date Prepared: March 8, 2004

Flow Rate in MSCFH STP = 60F/14.65 PSI.

Not Corrected for Compressibility

Flowing Media	Natural Gas
Pipeline I.D.	4.026 inches
Flowing Temperature	60 °F
Specific Gravity	0.60 air = 1.00
k-Factor ( $h=kV^2/2g$ )	2.00

Line PSIG	Flow Rates (MSCFH) at Various Differential Pressures							
	5" wc	10" wc	20" wc	1 PSID	2 PSID	3 PSID	4 PSID	5 PSID
10	56	80	113	132	187	229	265	296
20	67	94	133	157	222	272	314	351
30	76	107	151	178	252	309	357	399
40	84	118	168	197	279	342	394	441
50	91	129	182	215	303	372	429	480
60	98	138	196	230	326	399	461	515
75	107	152	215	253	357	438	505	565
100	121	172	243	286	404	495	571	639
150	145	206	291	342	484	593	685	765
200	166	235	332	391	553	677	782	874
300	201	284	402	473	669	820	946	1058
400	231	326	461	543	768	941	1086	1215
500	257	364	514	605	856	1048	1210	1353
600	281	397	562	661	935	1146	1323	1479
700	303	428	606	713	1009	1235	1426	1595
800	323	457	647	761	1077	1319	1523	1703
900	343	485	685	807	1141	1397	1614	1804
1000	361	510	722	850	1202	1472	1700	1900
1100	378	535	757	891	1260	1543	1781	1992
1200	395	558	790	930	1315	1610	1860	2079
1300	411	581	822	967	1368	1675	1935	2163
1400	426	603	852	1003	1419	1738	2007	2244
1500	441	624	882	1038	1468	1798	2077	2322

Represented By

**Apollo Engineering Company**  
 P.O. Box 2050  
 Broken Arrow, OK 74013

Telephone: (918)251-6780

**Apollo**

Engineering Company

P.O. Box 2050 Broken Arrow, OK 74013

Tel: (918)251-6780 FAX: (918)251-5986

Copyright © Apollo Engineering Company, 1998

**Fabricated in Accordance with the Latest Edition of the ASME  
Boiler and Pressure Vessel Code, Section VIII, Division 1**

Diameter	8.625"	O.D.	
Shell Length	37.250"	Seam to Seam	
Code Stamp	Optional	Other Specs	N.S.
Design Press.	1480	PSIG @	100 °F
Hydro. Press.	2220	PSIG @	40-100 °F
MDMT	-20	°F	1480 PSIG
Limited By	Flange	Radiograph	Spot
Joint Eff.	1.00	Heat Treat	No
Corr.Allow.	None	Wind Load	Std
Nozzle Proj.	Std	Dim'l Toler.	Std
Hinged Cover	No	Davit	No
Ladders	No	Platforms	No
Saddles	No	Insulation	No
Surface Prep.	SPPC SP2	Paint	Red Oxide Primer
Weight.	265 lbs	Volume	1.10 c.f.

Notes

**Materials**

Shell	SA106-B/C	Size	8"	Sch	XH
Nozzles	SA106-B/C	Size	4"	Sch	XH
QOC Hub	SA350-LF2	Size	8"	Sch	XH
QOC Cap	SA350-LF2	Heads	SA234-WPB		
Plate	SA516-70	Studs	SA193-B7, Plt'd		
Forgings	SA105	Nuts	SA194-2H, Plt'd		
BW Fittings	SA234-WPB	Gaskets	NonAsb		
Pipe	SA106-B/C	O-Rings	Nitrile		
Element Part No.	010-10-220608	Qty	1		
Gasket Part No.	030-10-002946	Qty	1		
Filter Cap Part No.	040-10-575350	Qty	1		
Wing Nut Part No.	040-10-575350	Qty	1		

Other

Notes

**Process Design Conditions**

Fluid	---	Notes	
Flow Rate	---	MSCFH	
Pressure	---	PSIG	
Temperature	---	°F	
Specific Gr.	---		
Pressure Drop	---	PSID	

**Schedule of Openings**

Mark	Qty	Size	Series	Facing	Type	Sch	Service
N1	1	4"	600#	RF	WN	XH	Inlet
N2	1	4"	600#	RF	WN	XH	Outlet
N3	1	8"	VQOC	O-Ring	Thr'd	XH	Service Entry
T1	1	1/2"	N/A	Thr'd	D&T	---	Vent
T2	1	1"	3000#	Thr'd	Cplg	---	Drain
T3	2	1/4"	N/A	Thr'd	D&T	---	D.P. Taps

Sketch depicts general arrangement - actual details may vary. For example, nozzle necks may be either weld-o-lets or pipe, nozzles may have repads, baseplates may not have gussets, etc.

Notes

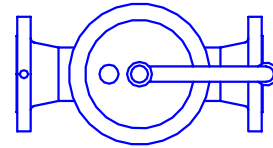

PLAN

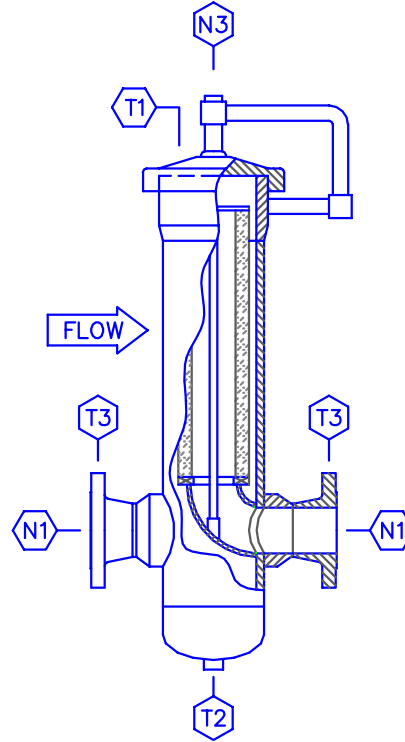

ELEVATION

Style CQ

Specification	AECo Std	ITEM  Model GFR-04-1440-Q Gas Pipeline Filter
Prepared By	JAC	
Date	9/26/2004	
Shop Order/Quote No.	Std	
Customer	AECo Users	TAG GFR-04-1440-Q

**Apollo Engineering Company**  
Broken Arrow, Oklahoma