

Mustang® Pressure Regulating Vaporizer Sampling System NGL Jr.

MPRVSSJR

U.S. Patent No. 9,285,299



SINGLE PATH VAPORIZER

SS INSULATED ENCLOSURE

OUTLET

SINGLE OR MULTI-STAGE
HEATED REGULATOR

TEMPERATURE CONTROLLER



Analytically Accurate® Technology

The Mustang® Pressure Regulating Vaporizer Sampling System (MPRVSS—NGL JR.) is a technology designed to vaporize liquid providing a fresh sample to a continuous online analyzer.

This system is designed with enhanced sample quality, through controlled vaporization and remixing, and gas sample pressure reduction.

In order for the analyzer to meet its stated accuracy, the Mustang® Pressure Regulating Vaporizer Sampling System ensures the sample to the analyzer is in a stable composition. The single-path design is suitable for sample conditioning where redundancy is not a concern.

- ▶ cETLus Certified
- ▶ ATEX/IECEX Certifiable Design Available
- ▶ Patented Technology
- ▶ Continuous gas flow design eliminating post-vaporization hydrocarbon liquid dropout
- ▶ Accurate and reliable representative sample for your GC
- ▶ Installs at gas stripping facilities and where heavier hydrocarbon measurements are required

PRODUCT DIMENSIONS

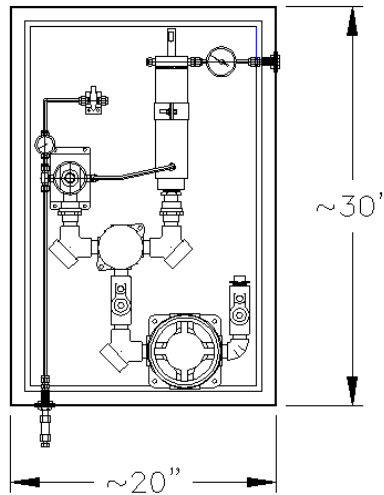

Fig. 1a—Mustang® Pressure Regulating Vaporizer Sampling System Jr.

PRODUCT SPECIFICATIONS

Maximum allowable working pressure	3750 psig (359 bar)
Proportional temperature control range	0°F-300°F (-18°C-148°C)
Port sizes	1/4" female NPT
Regulator	Single-stage MHR or Multi-stage MJTR
Power rating options	115 VAC, 590 Watts, 50/60 Hz, ± 10% 208 VAC, 590 Watts, 50/60 Hz, ± 10% 230 VAC, 590 Watts, 50/60 Hz, ± 10%
Wetted materials	Machined parts: 316 stainless steel/NACE compliant All other metal parts: stainless steel/NACE compliant; (other materials available upon request)

VAPORIZATION & REMIXING STAGES

- ▶ **STAGE 1**—Single-path unit designed to vaporize NGL and send the sample to the regulator for pressure reduction
- ▶ **STAGE 2**—A pre and post-heated pressure regulator designed to prevent hydrocarbon dew point dropout and reduce sample pressure which is then delivered to the heated liquid block



Mustang Sampling®

info@mustangsampling.com
www.mustangsampling.com

P 304-273-5357
F 304-273-2531
P.O. Box 490
Ravenswood, WV 26164



Locally Represented By: