

DANIEL®  
**SENIOR ORIFICE FITTING**  
SPARE PARTS KIT

---

**SLIDE VALVE CARRIER AND STRIP  
REPLACEMENT**

---

**DMC-20079588**

---

**DAN-20080016**

---

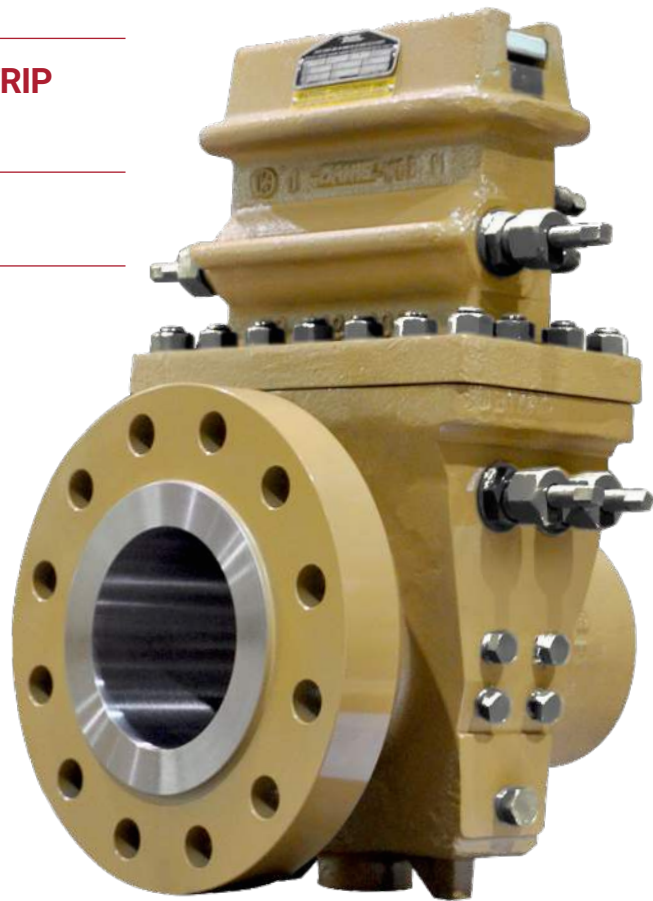

**DANIEL®**

## Slide Valve Carrier and Strip Replacement

### Important Safety Instructions

Daniel Measurement and Control, Inc. (Daniel) designs, manufactures and tests products to function within specific conditions. Because these products are sophisticated technical instruments, it is important that the owner and operators strictly adhere to the information printed on the product, to all instructions provided in the latest edition of Owner and Operator Manual No. 3-9008-001 and to all instructions provided in this spare parts manual prior to installation, operation, and maintenance.

The latest edition of Owner and Operator Manual No. 3-9008-001 can be found at the following address:

<https://daniel.com/differential-pressure/senior-dual-chamber-orifice-fittings/>

Daniel also urges you to use both this spare parts manual as well as the Owner and Operator Manual No. 3-9008-001 into your training and safety program.

BE SURE ALL PERSONNEL READ AND FOLLOW THE INSTRUCTIONS IN THIS DOCUMENT AND ALL NOTICES AND PRODUCT WARNINGS.

### **WARNING**

Installing, operating or maintaining a Daniel product improperly could lead to serious injury or death from explosion or exposure to dangerous substances. To reduce this risk:

- Comply with all product information in the document listed above, and with all local and national codes.
- Do not allow untrained personnel to work with this product.
- Use Daniel parts and work procedures specified on this instruction sheet

### Owners:

- Use the correct parts for the environment and pressures present. See technical data or product specifications for limitations.
- If you are unsure, discuss your needs with your Daniel representative.
- Inform and train all personnel in the proper repair or upgrading of this product.
- To ensure safe and proper performance, only informed and trained personnel should repair this product.
- Verify that this is the correct instruction sheet for your Daniel product. If these are not the correct instructions, contact Daniel at 1-713-827-6314.
- Save this instruction sheet for future reference.
- If you resell or transfer this product, it is your responsibility to forward this instruction sheet to the new owner or transferee.
- Do not use these parts for any purpose other than its intended service. This may result in property damage and/or serious personal injury or death.

### Users:

- To prevent personal injury, personnel must follow all instructions on this sheet prior to and during repair of the product.
- Follow all warnings, cautions, and notices marked on, and supplied with, this product.
- If you do not understand an instruction, or do not feel comfortable following the instructions, contact your Daniel representative for clarification or assistance.
- Install these components as specified in this instruction sheet and per all local and national codes.
- Use only replacement parts specified by Daniel. Unauthorized parts and procedures can affect this product's performance, safety, and invalidate the warranty. "Look-a-like" substitutions may result in deadly fire, explosion, toxic substance release or improper operation.
- Save this instruction sheet for future reference.

## Slide Valve Carrier and Strip Replacement

### Procedures

#### **⚠ WARNING**

Installing a component in a Daniel product improperly could lead to serious injury or death from explosion or exposure to dangerous substances. To reduce this risk:

- Follow the procedures below.
- Do not allow untrained personnel to work with this product.
- Use Daniel parts and work procedures specified in the documents listed above.

### In-Line Repair

Task List for Field Service Personnel for application of Repair Kits when unit is pressurized and in service.

#### 1. Before entering the work site:

- Familiarize yourself and follow all worksite procedures.
- Request the line-breaking permit from facility personnel or contractor before proceeding to work site.
- Review and understand the line-breaking permit. The permit should clearly state the scope of the work and the time allowed for the work.
- Review and understand the potential hazards involved such as dangerous gases, hot dusts, toxic atmosphere, steam, temperature, flammable or combustible liquids, and corrosives. Field Service personnel must have proper training and knowledge of the chemicals used at the facility.
- Request Material Safety Data Sheets (MSDS) associated with the work.
- Review and understand the information contained in the Material Safety Data Sheets.
- Review and discuss with site or contractor personnel the required personal protective equipment (PPE).
- Review, understand and discuss the facilities' Lock-Out-Tag-Out (LOTO) procedures.
- Review, understand and discuss the use of any safety equipment (*ladders, scaffolding, etc.*) and procedures required for the job.
- Review and understand the piping and instrument diagram (P&ID) of the work site.
- Review and understand the facilities' emergency evacuation procedure and emergency response plan.
- Confirm possession, and operation, of tools, manuals and PPE necessary to perform work.
- Sign-off and request a copy of the permit. Include the copy of the permit in any service report.
- If the permit does not state the scope of the work clearly, omits information concerning MSDS, PPE, LOTO, safety equipment and procedures, P&ID, or an emergency response plan then do not sign the permit and call your supervisor.
- Don PPE (*site specific*)

#### 2. At the work site:

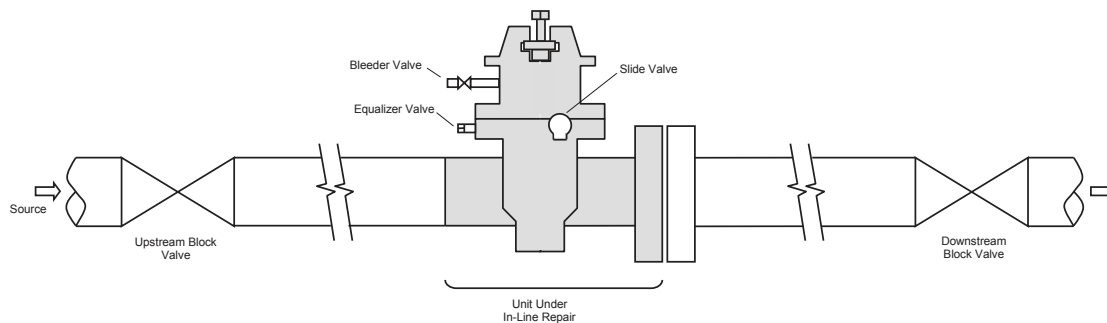

Figure 1: General Arrangement Diagram of a Senior Fitting in Service (In-Line)

### Slide Valve Carrier and Strip Replacement

1. Locate the emergency equipment (*fire extinguisher, eye wash/shower station, etc.*) and scout exit routes according to the site's evacuation plan.
2. Confirm that the P&ID matches the actual pipe configuration.
3. Have site or contractor personnel clear the area, post warning signs and permits, place barricades, and warn all personnel within the area.
4. Don PPE (*site specific*)
5. Begin line purge.
  - a. Close *Upstream Block Valve* Lock **CLOSED** (LOTO)
  - b. Close *Downstream Block Valve* Lock **CLOSED** (LOTO)
  - c. Ensure *Slide Valve* is open
  - d. Open *Bleeder Valve*
6. Observe pressure monitoring devices (*gauges, visual, auditory, etc.*)
7. Wait for line pressure to reduce to zero before beginning repair or part replacement
8. Safe line (LOTO)
9. Remove plate and plate carrier
10. Remove body/top hex nuts (not pictured)
11. Remove top (14). Set where no protruding parts will be bent or damaged and seat (18) is protected
12. Remove strip (3), which will either be stuck to seat (18) on top or resting on springs (15).
13. Remove springs (15), slide valve carrier guides (16), carrier (17), seat pins (17A), seat (18), and screws (18B)
14. Reassemble with the new strip (3), springs (15), slide valve carrier guides (16), and carrier (17)
15. Return all valves to their operating position
  - a. Close *Bleeder Valve*
  - b. Ensure *Slide Valve* is closed
16. Notify site and contractor personnel of work completion
17. Receive authorization to remove the LOTO
  - a. Open *Downstream Block Valve* Lock **OPEN** (LOTO)
  - b. Open *Upstream Block Valve* Lock **OPEN** (LOTO)
18. Begin line pressurization
19. Check lines for leaks – stop any leaks repeat leak check
20. Remove previously placed warning signs and barricades from the area

### 3. Outside of work site

- Remove PPE (site specific).
- Record the time and date of work completion.
- Complete work permit in full including signing and dating the form.
- Complete field service report.

### In-Shop Repair

Task List for Field Service Personnel for the application of Repair Kits when unit is unpressurized and in a shop.

- Review with shop personnel the scope of the work and the time allowed for the work.
- Request permission to perform your task from shop personnel or contractor before proceeding.
- Review and understand the shop safety rules.
- Review and discuss with site or contractor personnel the required personal protective equipment (PPE).
- Review and understand the potential hazards involved such as dangerous gases, hot dusts, toxic atmosphere, steam, temperature, flammable or combustible liquids, and corrosives.
- Machines and equipment in the shop shall be operated by authorized personnel only.
- Workers must not remove or make ineffective any safeguards in the shop, unless authorized.
- Gloves are recommended for protection in handling material.
- When placing or removing heavy components, personnel shall get help or crane service to prevent injury.
- Clean-up chips, spills, etc., on and around the work area after completing the tasks.

Slide Valve Carrier and Strip Replacement

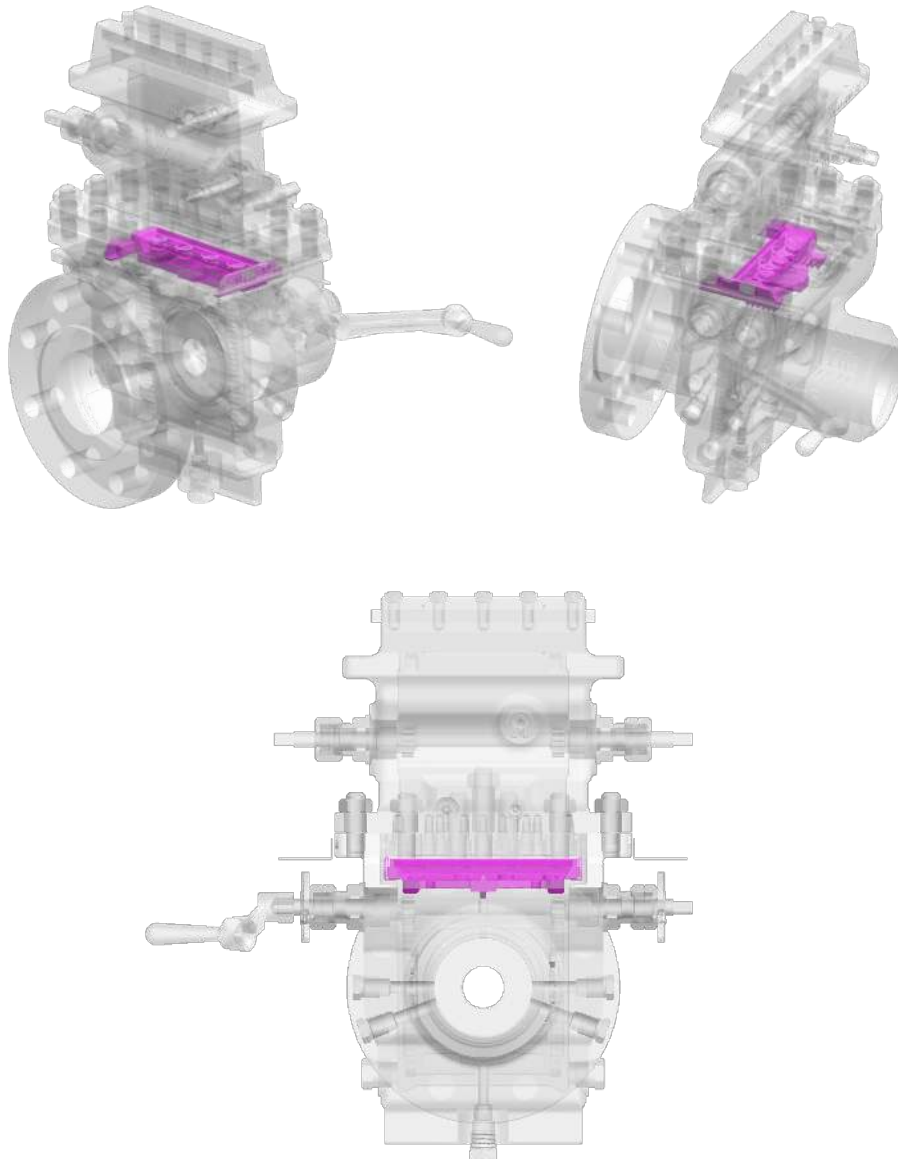

Slide Valve Carrier and Strip Replacement

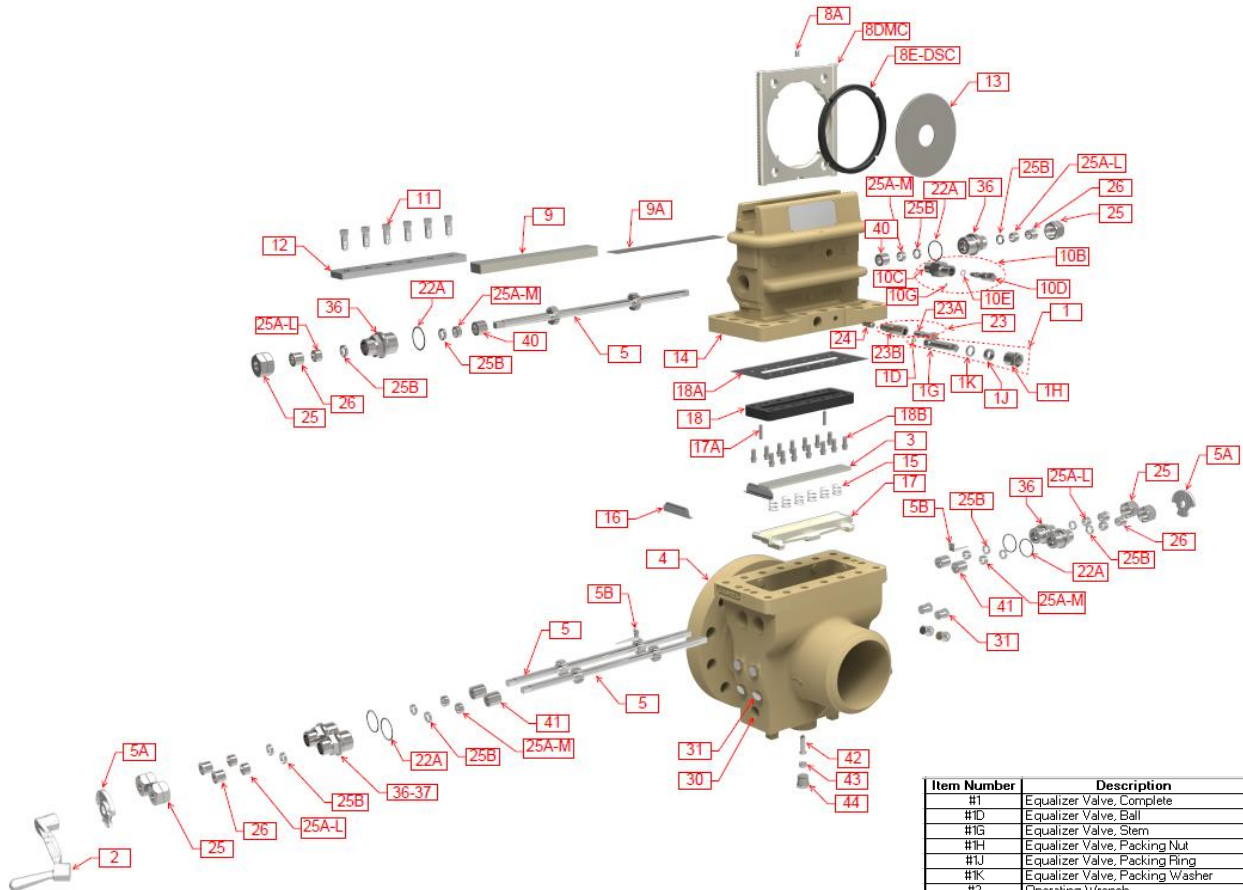

Item Number	Description
#1	Equalizer Valve, Complete
#1D	Equalizer Valve, Ball
#1G	Equalizer Valve, Stem
#1H	Equalizer Valve, Packing Nut
#1J	Equalizer Valve, Packing Ring
#1K	Equalizer Valve, Packing Washer
#2	Operating Wrench
#3	Slide Valve Strip
#5A	Indicator Plate LHFH
#5B	Indicator Pointer
#5	Gear Shaft
#9	Sealing Bar
#9A	Sealing Bar Gasket
#10B	Bleeder Valve, Complete
#10C	Bleeder Valve, Body
#10D	Bleeder Valve, Needle
#10E	Bleeder Valve, O-ring
#10G	Bleeder Valve, Set Screw
#11	Clamping Bar Screw
#12	Clamping Bar
#15	Slide Valve Spring
#16	Slide Valve Carrier Guide LHFH
#17	Slide Valve Carrier
#17A	Slide Valve Carrier Seat Pin
#18	Slide Valve Seat
#18A	Slide Valve Seat Top Gasket
#18B	Slide Valve Seat Screw
#22A	Bearing Plug/Stuffing Box Gasket
#23	Grease Gun, Complete
#24	Double Ball Check Valve
#25	Packing Nut
#25A-L	Packing Ring
#25A-M	Packing Ring
#25B	Centering Ring
#26	Stuffing Box Gland
#30	Drain Plugs
#31	Meter Tap Plugs
#36-37	Stuffing Box Body
#40	Stuffing Box Sleeve, Top
#41	Stuffing Box Sleeve, Body
#42	Plate Carrier Stop Pin
#43	Stop Pin Lock Screw
#44	Stop Pin Access Plug

With over 90 years of experience, Daniel is the only manufacturer that has the knowledge and experience to engineer and offer superior products that are trusted to provide the most reliable and accurate measurements in the global oil and gas industry.

**Contact Us**

Email: [Sales@Daniel.com](mailto:Sales@Daniel.com)  
Phone: +1 (346)-509-3700



[www.Daniel.com](http://www.Daniel.com)