

DANIEL®
SENIOR™ ORIFICE FITTING
TECHNICAL GUIDE

Differential Pressure Flow Meter

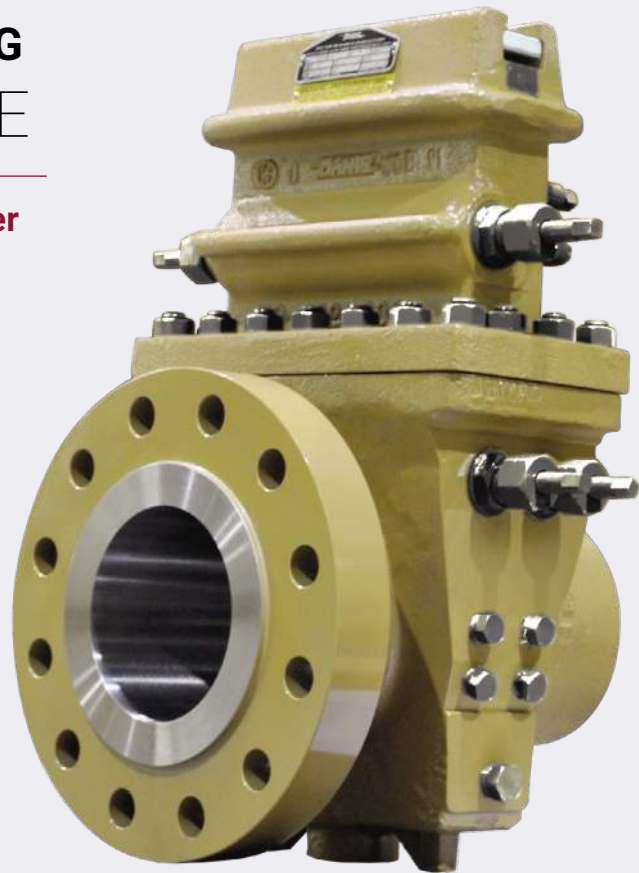

DANIEL®
Decades Proven. Field Chosen.™

SENIOR DUAL-CHAMBER ORIFICE FITTING

Accurate, reliable and easy-to-use

The Daniel Senior Orifice Fitting is a dual-chamber device that reigns as the most widely used means of measurement for natural gas. With an installed base of well over one million orifice fittings worldwide, more natural gas is measured with the Daniel Senior Orifice Fitting than any other type of device.

The Senior Orifice Fitting saves users time and money by providing a fast, safe and simple method of changing orifice plates under pressure without flow interruption. The dual-chamber design eliminates a need for costly piping bypasses such as additional valves and fittings required with conventional orifice flange installations.

Important facts about Daniel fittings

- The orifice plate carrier ensures compliance with strict eccentricity requirements of the API 14.3 and ISO 5167 standards by using metal-to-metal orifice plate alignment in 8-in line size fittings and smaller.
- The plate carrier allows for high differential pressure plate changes.
- Orifice plate carrier and plate alignment for 2-in to 8-in fittings are not field adjustable. This insures the fitting maintains factory conditions.
- One seal ring may be used for all pipe schedules in a given line size (up to Schedule 30 or Standard, whichever is larger) to meet API 14.3 and ISO 5167 requirements for seat gaps. (This reduces the need to purchase multiple seal rings.)
- Field-repairable, reducing downtime and costs associated with shipping to a repair site.
- A variety of materials make the fitting an ideal solution for sour gas and other special applications. Corrosion resistant and other special casting materials, including Wrought Carbon Steel (WCC, WCB), Low Temperature Carbon Steel (LCC), 316 Stainless Steel and Duplex, make this fitting an ideal solution for sour gas service and other special applications.
- The plate seals are located on both the upstream and downstream side of the plate and seat faces and are more commonly known as dual face seals.
- Four (4) pairs of pressure taps are standard on 2-in to 24-in ANSI 600 Daniel dual-chamber fittings.
- The slide valve metal to metal seat, (hard seat⁽¹⁾), contains lubricant that is ideal for dirty applications, providing an optimal seal in the production environment where particulate matter is common.
- Optional soft seat slide valve⁽²⁾ (O-ring seal without lubricant) is available in 2-in to 12-in fittings up to ANSI Class 600 for use with clean gas products, including ethylene.
- All Daniel Senior Orifice Fittings are hydrostatically tested.

(1) Hard-seat using injected grease / sealant is recommended for production applications where sand, grit and other particulate matter is present.

(2) Soft-seat, greaseless seal is not recommended / intended for production applications where sand, grit and other particulate matter is commonly present (e.g., shale gas production).

Major components

Plate sealing units

Provides a secure seal between the orifice plate and body seat and can be used for a variety of services.

Plate carrier

Protects the orifice plate during insertion or removal and can be easily inserted while the fitting is installed in the horizontal position.

Indicator plate

Clearly shows the position of the slide valve within the fitting.

Operation

Senior Fittings 2-in to 12-in and smaller line size fittings can operate in a vertical down flow condition or positioned in horizontal flow for side opening.

Typical applications

- Pipelines
- Gas distribution
- Offshore and onshore gas production
- Gas processing plants
- Floating production, storage and offloading (FPSO)
- CO₂ injection

Standard specifications

Please consult an Daniel product specialist if requirements are outside of the listed specifications. Other product and material offerings may be available depending on the application.

Mechanical ratings

Pressure rating by line size

- Standard: 2-in to 12-in, ANSI 600, 16-in to 24-in, ANSI 150-600
- Consult factory for other options over ANSI 600

End connections

Body styles

- Standard: Flangnek Raised Face (FN/RF) and Flangnek Ring-Type Joint (FN/RTJ)
- Optional: Flanged Raised Face (FF/RF), Flanged Ring-Joint (FF/RTJ)

Differential pressure taps

Internal tap holes sizes

- Standard: In accordance with API 14.3 (AGA3)
- Optional: In accordance with ISO 5167

Process connection

- Standard: .50-in NPT standard
- Consult factory for other options

Telemetry taps

- Standard on ANSI 600
- Consult factory for other ANSI classes

Line bore

- Standard Size: Sch 40, 80, and 160
- Consult factory for other options

Quality assurances

- Hydrostatic test 1.50 times rated CWP
- Meets or exceeds API 14.3 requirements for positive plate seal, pressure tap integrity, seal protrusion and eccentricity

Temperature range

- Standard: -20°F to +200°F (-29°C to +93°C)
- Standard (low temperature): -50°F to +200°F (-46°C to +93°C)
- Consult factory for other options

Material specifications (body casting)

- Standard: A126 GR. WCB
- Standard (low temperature applications): A352 GR. LCC
- Consult factory for other options

Operating shafts

- All fittings come standard with stainless steel, double-ended shafts. (Eliminates the need to reverse shafts in the field.)

Trim material

- Standard: NACE trim on 2-8-in 600#. A trim in all others.
- Consult factory for other options

Table 1: Fluid conditions and Trim packages available

Trim options	A	NACE	AASG	316SS PIC	22CR Duplex
Fluid Type	Dry 'sweet' gas	Dry 'sour' gas	Liquid or wet 'sour' gas	Liquid or wet 'sour' gas	Liquid or wet 'sour' gas
H ₂ S present	No	Yes	Yes	Yes	Yes
H ₂ O present	No	No	Yes	Yes	Yes
Corrosive	No	No	Mildly	Moderately	Severely
MPY	0	0	≤3.0	>3.0 to 8.0	>3.0 to 8.0

MPY = mils (0.0001) penetration per year of corrosion on carbon steel

Flange alignment

- On 16-in to 24-in, ANSI 300 or smaller, three dowel pin flange-alignment holes are drilled in the flanges.
- On Daniel ANSI 600 fittings or higher, flanges are manufactured with close-tolerance, large male flange-facing on fitting.

Note

Companion flanges are available upon request.

Figure 1: Method of aligning meter tube flange to Orifice Fitting Flange

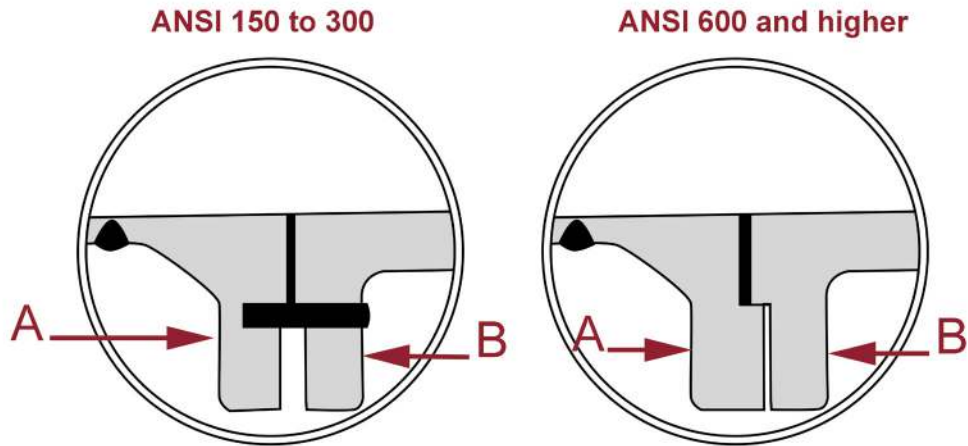

A. Meter tube flange

B. Fitting flange

Table 2: Pressure ratings available by line size for Daniel Senior Orifice Fittings

ANSI Class	Line size (in)									
	2	3	4	6	8	10	12	16	20	24
150								•	•	•
300								•	•	•
600	•	•	•	•	•	•	•	•	•	•
900	•	•	•	•	•	•	•	•	•	
1500	•	•	•	•	•	•	•	•	•	
2500	CF	CF	CF	CF						

• : available in this line size and ANSI class

CF: Consult factory

Plate carrier for 2-in to 8-in Senior Orifice Fittings

The Daniel orifice plate carrier uses a four-point positioning system that ensures superior concentricity within the fitting in accordance with the API 14.3 (AGA 3) and ISO 5167 standards (see [Figure 4](#)). Metal-to-metal contact of the plate outer diameter with the inner diameter of the orifice plate carrier, coupled with precision contact points of the orifice plate carrier to the fitting, offers users consistent compliance with AGA eccentricity requirements in a vertical or horizontal plane.

The Daniel plate carrier is compatible with Daniel Senior Orifice Fittings manufactured after 1992. For upgrade information, please contact your local Daniel representative.

Figure 2: Design features

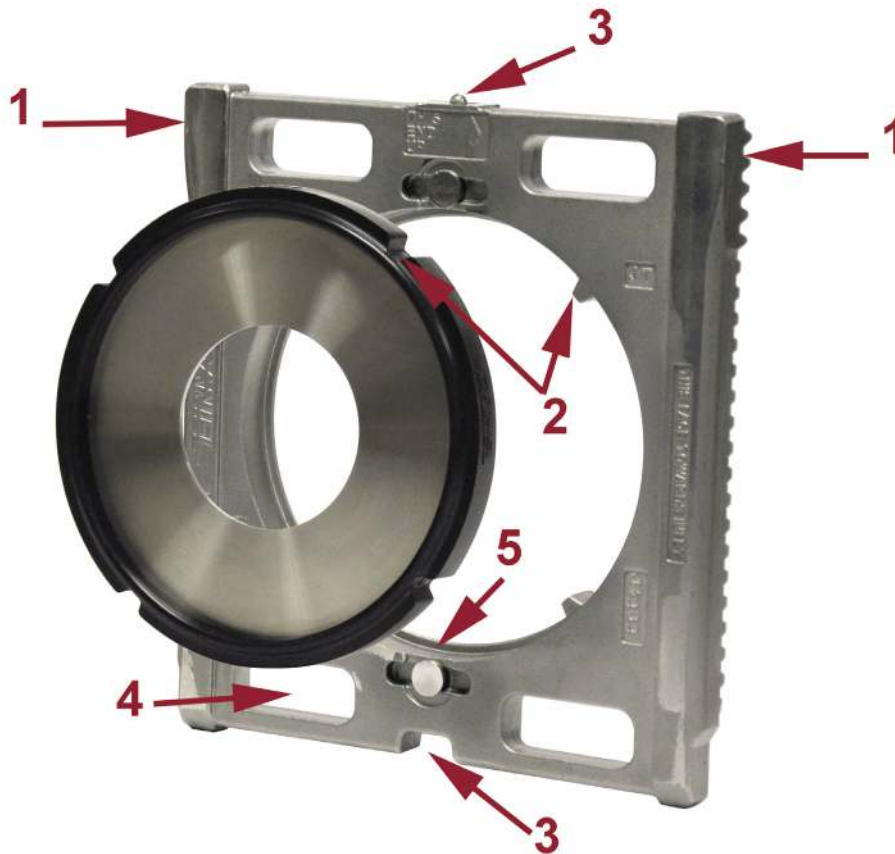

1. Precision ground corner tabs keep the orifice plate carrier in the proper position and allow the fitting to be mounted in the nine, twelve or three o'clock position (see [Figure 5](#) on page 8).
2. Notched seal ring design provides metal-to-metal contact for reliable alignment and centering of the orifice plate.
3. The fitting's pin and the spring loaded button located at the top of the orifice plate carrier ensure tight positioning of the plate carrier when the slide valve is closed and the Senior Orifice Fitting is in the vertical or horizontal metering position (see [Figure 3](#) on page 7).
4. Wide flow ports reduce differential pressure load across the plate surface during a plate change.
5. A 360° seal ring support shelf secures the plate in place.

Orifice plate installation

NOTICE

This view is a representation only and is not intended for use as a field guide to operations. See Senior Orifice Fitting user manual (P/N 1-3-9008-001) and always read and follow the detailed operating instructions provided with each fitting before attempting operation.

The figure below demonstrates the top chamber in the opened position with the plate carrier in place for change or inspection of the plate.

Figure 3: Orientation of plate carrier prior to installation

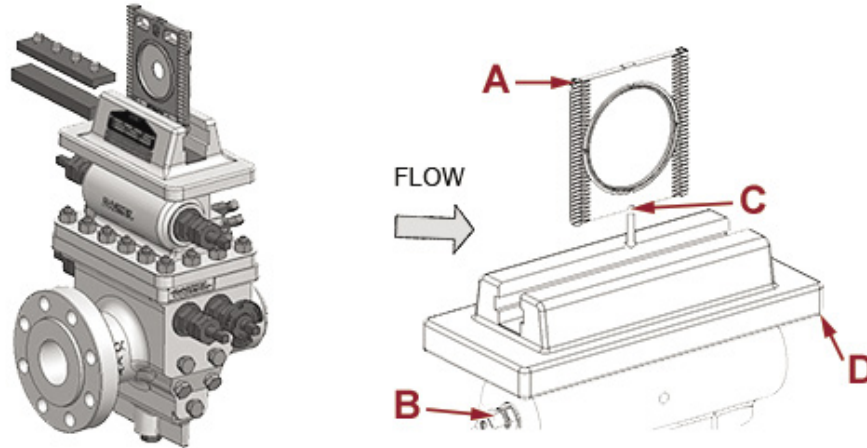

- A. Daniel plate carrier assembly
- B. Plate carrier gear shaft
- C. "Notch" down
- D. Daniel Senior Fitting

The figure below demonstrates the slide valve in the closed position and the orifice plate concentric to the line of flow. The slide valve cannot be closed unless the orifice plate is concentric to the bore of the fitting or is in the upper chamber during plate removal.

Figure 4: Side sectional view of Daniel Senior Orifice Fitting

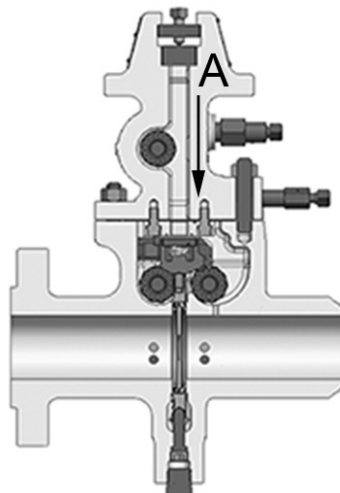

- A. Plate carrier travels down into the measurement position

Figure 5: Metering positions

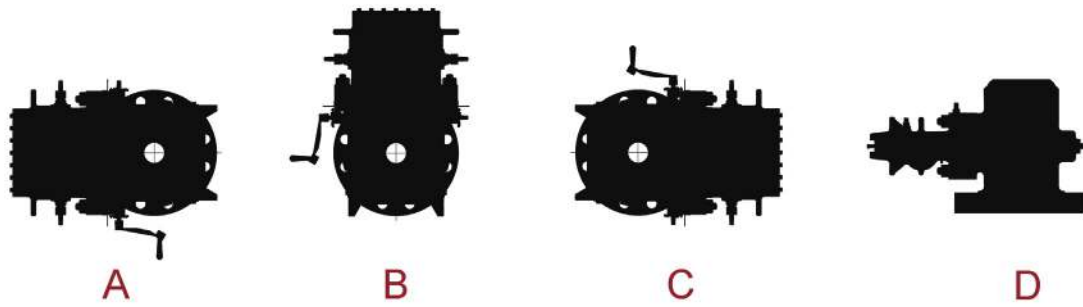

- A. Nine O'Clock (Far side)
- B. Twelve O'Clock
- C. Three O'Clock (Near side)
- D. Vertical down

Slide valve

Figure 6: Slide Valve / Isolation Mechanism⁽³⁾

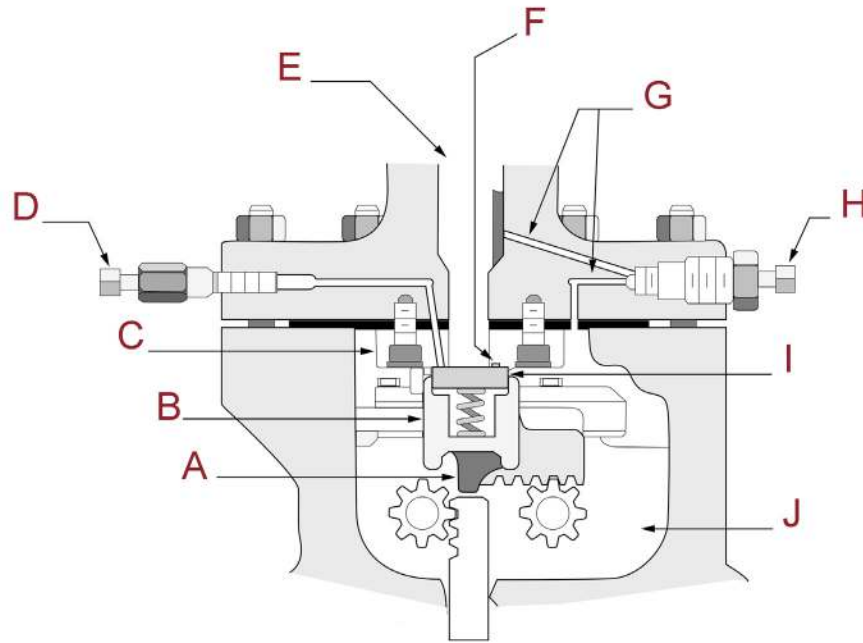

A. The slide valve carrier features a pad that retains the orifice plate carrier in the lower chamber to ensure compliance with API 14.3 eccentricity requirements.

B. Slide valve carrier (Part No. 17)

C. Slide valve seat (Part No. 18)

D. Grease gun (Part No. 23)

E. Top chamber

F. Continuous grease groove (encircles valve opening)

G. Equalizer passageways

H. Equalizer valve (Part No. 1)

I. Slide valve strip (Part No. 3)

J. Lower chamber

Valve strip (Part No. 3), and valve seat (Part No. 18) create the metal to metal seal. Slide valve carrier (Part No. 17) is moved by turning the operating wrench.

Before opening the slide valve, lubricant is injected using the grease gun (Part No. 23). Next, the equalizer valve (Part No. 1) is operated to equalize pressure throughout the fitting, allowing the slide valve to move freely without wear.

The metal-to-metal seal with lubricant ensures an optimal seal, particularly in production environments where sand and particulate matter are common.

(3) Hard seat configuration shown.

Daniel lubricant

Daniel lubricant is specifically designed for lubricating the slide valve of Senior Orifice Fittings, ensuring maximum operating performance. This lubricant has significant advantages:

- Tested over a wide range of demanding temperatures (-20°F to +160°F) and pressures (up to 1,400 psig)
- Contains no fillers or inert materials, reducing hardening or oxidizing.
- Different types of lubricants⁽⁴⁾ are available to meet the various demanding needs of gas applications.
- Daniel lubricant is available in B-sized sticks (.375-in diameter, 1.5-in long), with 24 sticks per box.

Important

For more specific information on lubrication, refer to Section 5.2 of the Senior Orifice Fitting manual (P/N 1-3-9008-001)

Figure 7: Grease types



(4) Grease sticks must be ordered separately. Consult with an Daniel technical specialist to confirm the correct type of grease for the application.

Figure 8: Grease gun

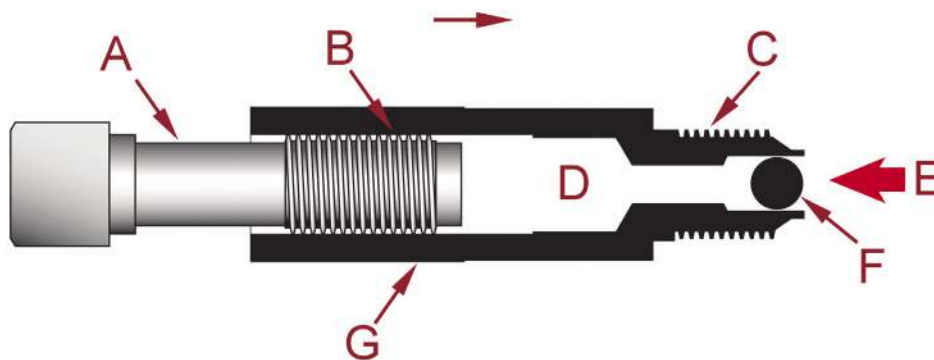
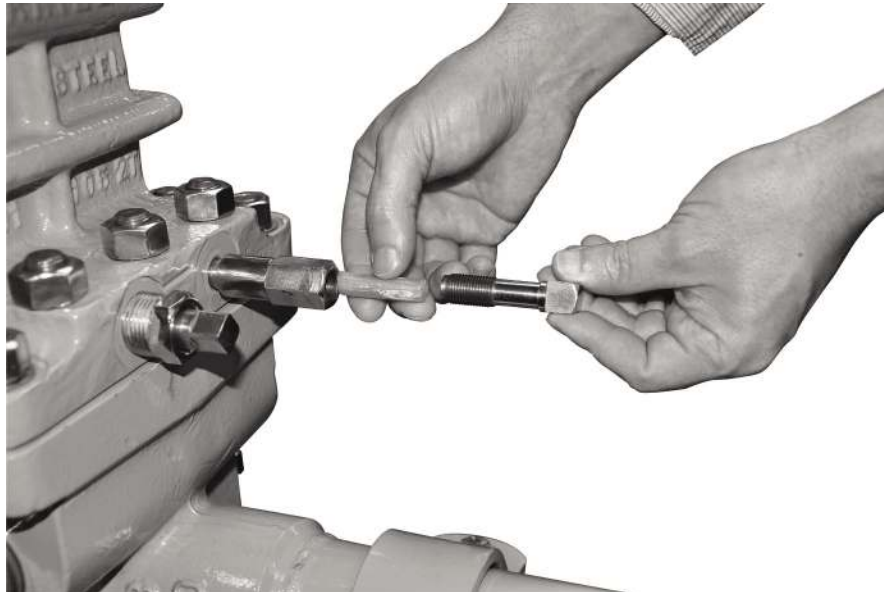

- A. Stem
- B. Threaded section plunger
- C. Threaded section of grease gun body fastened into Senior Fitting top
- D. Grease receiver-body
- E. Internal fluid pressure contained in the Fitting
- F. One-way check valve ball
- G. Grease gun body

WEIGHTS AND DIMENSIONS

Daniel Senior™ Orifice Fitting with Flangnek Raised Face 2-in to 16-in ANSI 150 to 900

The dimensional diagrams in [Figure 9](#) below indicate the component measurements provided in the charts on this page. All weights and dimensions are based on standard material offerings.

Figure 9: Daniel Senior™ Fitting with Flangnek™ Raised Face available in 2-in to 16-in ANSI 150 to 900

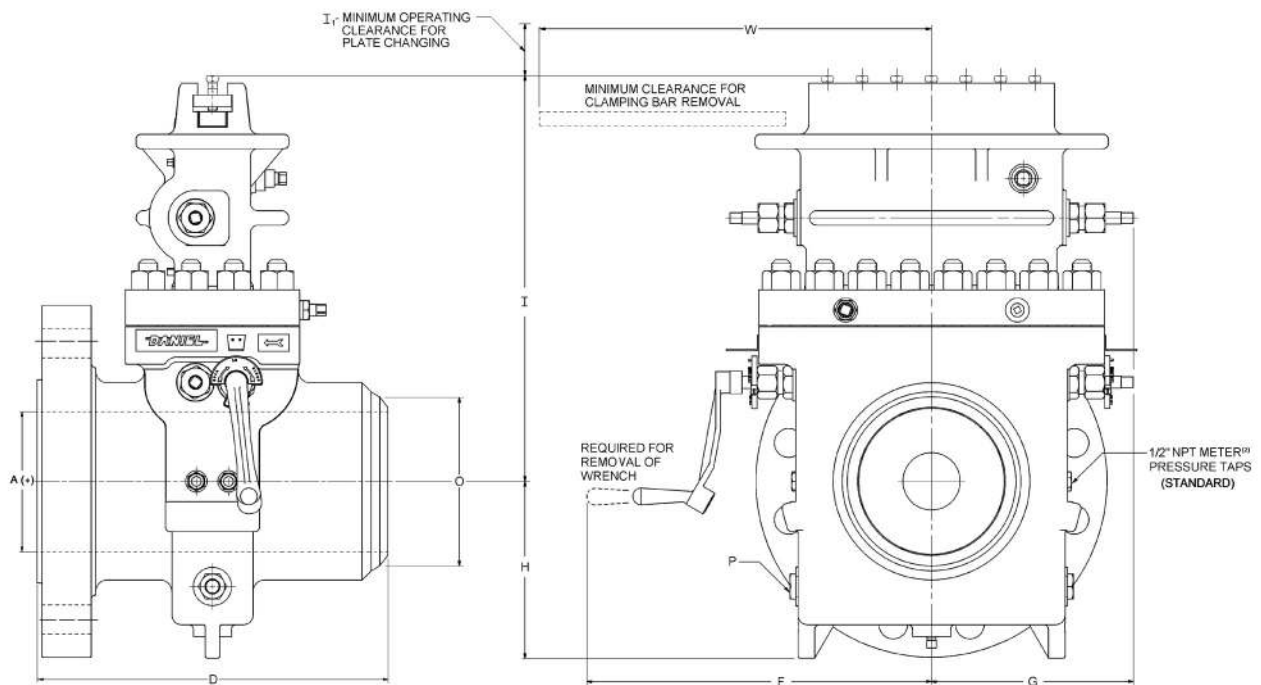

(*) 'A' represents the internal line bore size of the fitting. Consult factory for the complete range of available bore sizes.

ANSI 600 Daniel Flangnek-Raised Face 2-in to 16-in									
Lines size (in)		2	3	4	6	8	10	12	16
Weight (lb)		105	160	265	400	595	745	1,215	2,315
Standard trim ⁽¹⁾		NACE	NACE	NACE	NACE	NACE	A	A	A
Overall face to face dimension (in)	D	10.62	14.00	13.25	16.00	17.50	17.25	18.88	21.62
Operating clearances from center (in)	F	13.00	14.00	15.00	16.00	17.00	18.00	20.00	24.00
Body clearance from center (in)	G	7.00	8.00	9.00	10.00	11.00	12.00	14.00	18.00
Clearance to bottom (in)	H	6.00	6.00	7.00	8.00	9.00	10.00	12.00	14.00

(1) Consult factory for other trim options for severe service and other code requirements, including low-temperature, high H₂S, high CO₂, ISO 5167, PED, Daniel "AASG" and special applications.

Continued on the next page

Continued from the previous page

ANSI 600 Daniel Flangnek-Raised Face 2-in to 16-in									
Lines size (in)		2	3	4	6	8	10	12	16
Centerline to top (in)	I	14.00	15.00	16.00	19.00	22.00	25.00	28.00	36.00
Clearance for plate changing (in)	I ₁	6.00	7.00	8.00	10.00	12.00	14.00	16.00	20.00
Diameter hub at point of welding (in)	O	2.47	3.59	4.62	6.78	8.78	10.94	12.97	16.25
Size of "NPT" drain plugs (in) ⁽²⁾	P	0.50	0.50	0.75	1.00	1.00	1.00	0.75	0.75
Orifice plate thickness (in) ⁽³⁾		0.12	0.12	0.12	0.12	0.25	0.25	0.25	0.38
Minimum clearance for clamping bar removal (in)	W	9.00	11.00	13.00	16.00	19.00	22.00	26.00	36.00

(2) Flanged process connections available.

(3) Standard plate thickness provided. Consult factory for additional plate thickness options.

ANSI 150 Daniel Flangnek-Raised Face 16-in	
Lines size (in)	16
Weight (lb)	1,255
Standard trim ⁽¹⁾	A
Overall face to face dimension (in)	D 15.25
Operating clearance from center (in)	F 24.00
Body clearance from center (in)	G 18.00
Clearance to bottom (in)	H 12.00
Centerline to top (in)	I 36.00
Clearance for plate changing (in)	I ₁ 20.00
Clearance for plate changing (in)	O 16.25
Size of "NPT" drain plugs ⁽²⁾ (in)	P 0.75
Orifice plate thickness (in) ⁽³⁾	0.38
Minimum clearance for clamping bar removal (in)	W 34.00

(1) Consult factory for other trim options for severe service and other code requirements, including low-temperature, high H₂S, high CO₂, ISO 5167, PED, Daniel "AASG" and special applications.

(2) Flanged process connections available.

(3) Standard plate thickness provided. Consult factory for additional plate thickness options.

ANSI 300 Daniel Flangnek-Raised Face 16-in	
Lines size (in)	16
Weight (lb)	1,590
Standard trim ⁽¹⁾	A
Overall face to face dimension (in)	D 16.12
Operating clearance from center (in)	F 24.00
Body clearance from center (in)	G 18.00
Clearance to bottom (in)	H 13.00

(1) Consult factory for other trim options for severe service and other code requirements, including low-temperature, high H₂S, high CO₂, ISO 5167, PED, Daniel "AASG" and special applications.

Continued on the next page

Continued from the previous page

ANSI 300 Daniel Flangnek-Raised Face 16-in		
Lines size (in)		16
Centerline to top (in)	I	36.00
Clearance for plate changing (in)	I ₁	20.00
Clearance for plate changing (in)	O	16.25
Size of "NPT" drain plugs ⁽²⁾ (in)	P	0.75
Orifice plate thickness (in) ⁽³⁾		0.38
Minimum clearance for clamping bar removal (in)	W	34.00

(2) Flanged process connections available.

(3) Standard plate thickness provided. Consult factory for additional plate thickness options.

ANSI 900 Daniel Flangnek-Raised Face 2-in to 16-in (use PTFE Seal Ring or SSR only)									
Lines size (in)		2	3	4	6	8	10	12	16
Weight (lb)		205	215	300	490	1,095	1,555	1,935	CF
Standard trim ⁽¹⁾		A	A	A	A	A	A	A	A
Overall face to face dimension (in)	D	14.00	14.00	15.00	16.62	18.38	21.88	23.38	22.69
Operating clearances from center (in)	F	13	14	15	16	17	19	21	26
Body clearance from center (in)	G	7.00	8.00	9.00	10.00	11.00	13.00	15.00	20.00
Clearance to bottom (in)	H	6.00	6.00	7.00	8.00	10.00	12.00	12.00	14.00
Centerline to top (in)	I	14.00	15.00	16.00	19.00	22.00	25.00	28.00	36.00
Clearance for plate changing (in)	I ₁	6.00	7.00	8.00	10.00	12.00	14.00	16.00	20.00
Diameter hub at point of welding (in)	O	2.47	3.59	4.62	6.78	8.78	10.94	12.97	16.25
Size of "NPT" drain plugs (in) ⁽²⁾	P	0.50	0.50	0.75	0.75	0.75	0.75	0.75	0.75
Orifice plate thickness (in) ⁽³⁾		0.12	0.12	0.12	0.12	0.25	0.25	0.25	0.38
Minimum clearance for clamping bar removal (in)	W	11.00	11.00	13.00	16.00	20.00	26.00	28.00	36.00

(1) Consult factory for other trim options for severe service and other code requirements, including low-temperature, high H₂S, high CO₂, ISO 5167, PED, Daniel "AASG" and special applications.

(2) Flanged process connections available.

(3) Standard plate thickness provided. Consult factory for additional plate thickness options.

Daniel Senior Orifice Fitting with Flangnek Ring Joint 2-in to 16-in ANSI 600-900

The dimensional diagrams in [Figure 10](#) below indicate the component measurements provided in the charts on this page. All weights and dimensions are based on standard material offerings. The certified approval drawing will include the actual weights and dimensions.

Figure 10: Daniel Senior Orifice Fitting with Flangnek™ Ring Joint available in 2-in to 16-in ANSI 600 and 2-in to 16-in ANSI 900

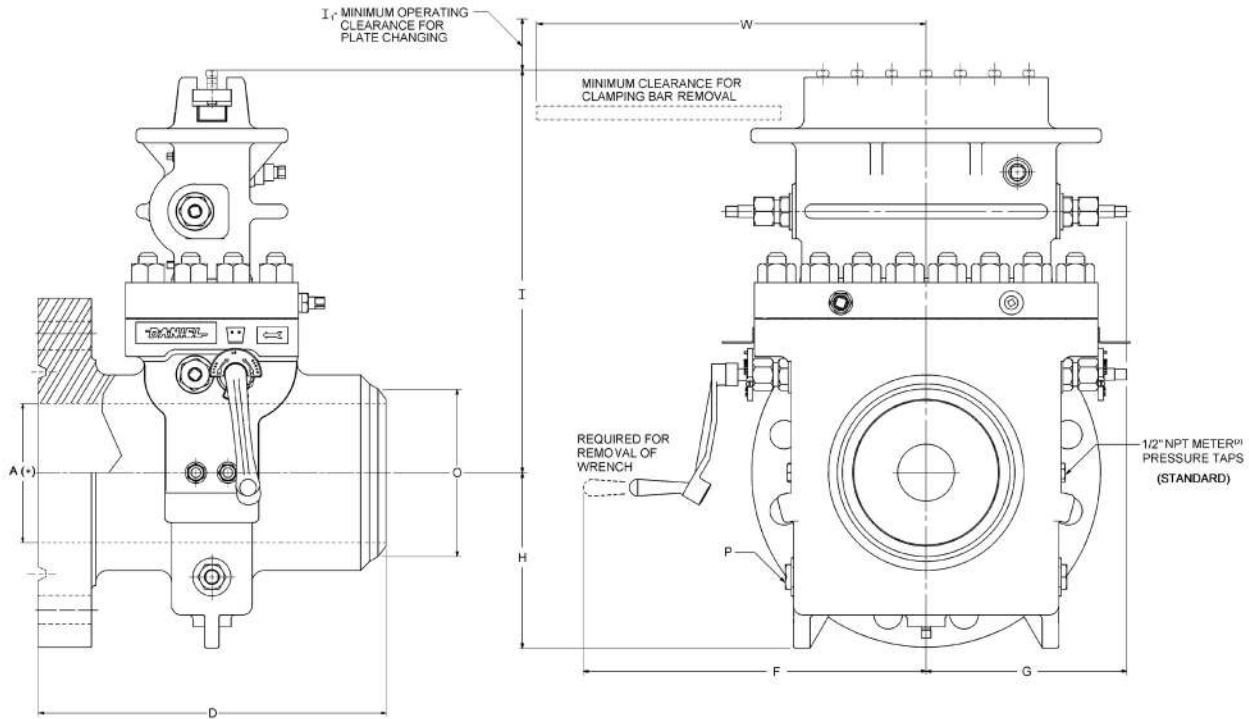

(*) 'A' represents the internal line bore size of the fitting. Consult factory for the complete range of available bore sizes.

ANSI 600 Daniel Flangnek-Ring Joint 2-in to 16-in									
Lines size (in)		2	3	4	6	8	10	12	16
Weight (lb)		105	160	265	400	595	745	1,215	2,315
Standard trim ⁽¹⁾		NACE	NACE	NACE	NACE	NACE	A	A	A
Overall face to face dimension (in)	D	10.80	14.10	13.40	16.10	17.60	17.40	19.00	21.80
Operating clearances from center (in)	F	13	14	15	16	17	18	20	24
Body clearance from center (in)	G	7.00	8.00	9.00	10.00	11.00	12.00	14.00	18.00
Clearance to bottom (in)	H	6.00	6.00	7.00	8.00	9.00	10.00	12.00	14.00
Centerline to top (in)	I	14.00	15.00	16.00	19.00	22.00	25.00	28.00	36.00
Clearance for plate changing (in)	I ₁	6.00	7.00	8.00	10.00	12.00	14.00	16.00	20.00

(1) Consult factory for other trim options for severe service and other code requirements, including low-temperature, high H₂S, high CO₂, ISO 5167, PED, Daniel "AASG" and special applications.

Continued on the next page

Continued from the previous page

ANSI 600 Daniel Flangnek-Ring Joint 2-in to 16-in									
Lines size (in)		2	3	4	6	8	10	12	16
Diameter hub at point of welding (in)	O	2.47	3.59	4.62	6.78	8.78	10.94	12.97	16.25
Size of "NPT" drain plugs (in) ⁽²⁾	P	0.50	0.50	0.75	1.00	1.00	1.00	0.75	0.75
Orifice plate thickness (in) ⁽³⁾		0.12	0.12	0.12	0.12	0.25	0.25	0.25	0.38
Minimum clearance for clamping bar removal (in)	W	9.00	11.00	13.00	16.00	19.00	22.00	26.00	36.00

(2) Flanged process connections available.

(3) Standard plate thickness provided. Consult factory for additional plate thickness options.

ANSI 900 Daniel Flangnek-Ring Joint 2-in to 16-in (use PTFE Seal ring or SSR only)									
Lines size (in)		2	3	4	6	8	10	12	16
Weight (lb)		205	215	300	490	1,095	1,555	1,935	CF
Standard trim ⁽¹⁾		A	A	A	A	A	A	A	A
Overall face to face dimension (in)	D	14.12	14.12	15.12	16.75	18.50	22.00	23.50	23.00
Operating clearances from center (in)	F	13.00	14.00	15.00	16.00	17.00	19.00	21.00	26.00
Body clearance from center (in)	G	7.00	8.00	9.00	10.00	11.00	12.00	14.00	18.00
Clearance to bottom (in)	H	6.00	6.00	7.00	8.00	10.00	12.00	12.00	14.00
Centerline to top (in)	I	14.00	15.00	16.00	19.00	22.00	25.00	28.00	36.00
Clearance for plate changing (in)	I ₁	6.00	7.00	8.00	10.00	12.00	14.00	16.00	20.00
Diameter hub at point of welding (in)	O	2.47	3.59	4.62	6.78	8.78	10.94	12.97	16.25
Size of "NPT" drain plugs (in) ⁽²⁾	P	0.50	0.50	0.75	0.75	0.75	0.75	0.75	0.75
Orifice plate thickness (in) ⁽³⁾		0.12	0.12	0.12	0.12	0.25	0.25	0.25	0.38
Minimum clearance for clamping bar removal (in)	W	11.00	11.00	13.00	16.00	20.00	26.00	28.00	36.00

(1) Consult factory for other trim options for severe service and other code requirements, including low-temperature, high H₂S, high CO₂, ISO 5167, PED, Daniel "AASG" and special applications.

(2) Flanged process connections available.

(3) Standard plate thickness provided. Consult factory for additional plate thickness options.

Daniel Senior Orifice Fitting Flangnek Raised Face 2-in to 16-in ANSI 1500 and 2-in to 12-in ANSI 2500

The dimensional diagrams in [Figure 11](#) below indicate the component measurements provided in the charts on this page. All weights and dimensions are based on standard material offerings. The certified approval drawing will include the actual weights and dimensions.

Figure 11: Daniel Senior Orifice Fitting Flangnek™ Raised Face available in 2" to 16" ANSI 1500 and 2" to 12" ANSI 2500

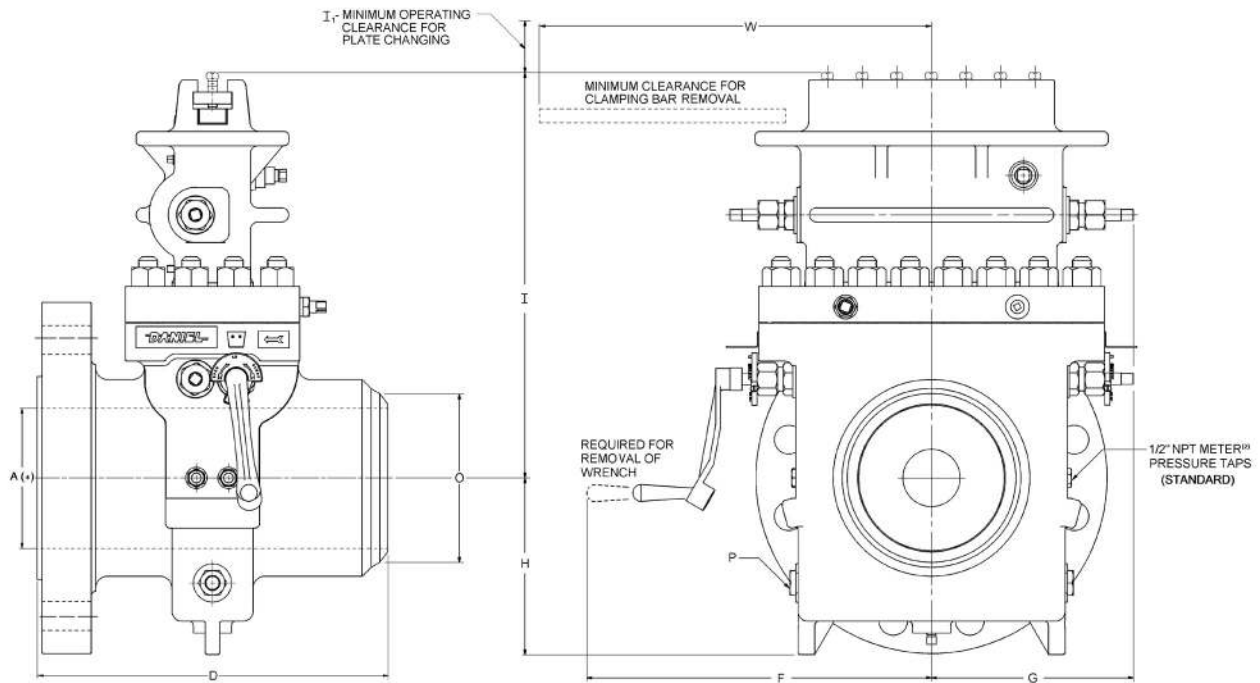

(*) 'A' represents the internal line bore size of the fitting. Consult factory for the complete range of available bore sizes.

ANSI 1500 Daniel Flangnek-Raised Face 2-in to 16-in (use PTFE Seal ring or SSR only)									
Lines size (in)		2	3	4	6	8	10	12	16
Weight (lb)		205	275	445	710	1,240	1,745	2,805	CF
Standard trim ⁽¹⁾		A	A	A	A	A	A	A	A
Overall face to face dimension (in)	D	14.00	16.00	16.38	21.06	23.12	24.88	26.88	29.00
Operating clearances from center (in)	F	13.00	14.00	16.00	16.00	18.00	19.00	23.00	28.00
Body clearance from center (in)	G	7.00	8.00	10.00	10.00	12.00	13.00	17.00	22.00
Clearance to bottom (in)	H	6.00	6.00	7.00	8.00	10.00	12.00	14.00	17.00
Centerline to top (in)	I	14.00	15.00	17.00	20.00	23.00	26.00	29.00	36.00
Clearance for plate changing (in)	I ₁	6.00	7.00	8.00	10.00	12.00	14.00	16.00	20.00
Diameter hub at point of welding (in)	O	2.47	3.59	4.62	6.78	8.78	10.94	12.97	16.25

(1) Consult factory for other trim options for severe service and other code requirements, including low-temperature, high H₂S, high CO₂, ISO 5167, PED, Daniel "AASG" and special applications.

Continued on the next page

Continued from the previous page

ANSI 1500 Daniel Flangnek-Raised Face 2-in to 16-in (use PTFE Seal ring or SSR only)									
Lines size (in)		2	3	4	6	8	10	12	16
Size of "NPT" drain plugs (in) ⁽²⁾	P	0.50	0.50	0.75	0.75	0.75	0.75	0.75	0.75
Orifice plate thickness (in) ⁽³⁾		0.12	0.12	0.12	0.12	0.25	0.25	0.25	0.38
Minimum clearance for clamping bar removal (in)	W	11.00	13.00	16.00	20.00	22.00	26.00	30.00	36.00

(2) Flanged process connections available.

(3) Standard plate thickness provided. Consult factory for additional plate thickness options.

ANSI 2500 Daniel Flangnek-Raised Face 2-in to 12-in (use PTFE Seal ring or SSR only)					
Lines size (in)		2	3	4	6
Weight (lb)		520	575	715	1,195
Standard trim ⁽¹⁾		A	A	A	A
Overall face to face dimension (in)	D	17.38	19.25	21.12	25.12
Operating clearances from center (in)	F	16.00	16.00	17.00	18.00
Body clearance from center (in)	G	10.00	10.00	11.00	12.00
Clearance to bottom (in)	H	7.00	7.00	8.00	12.00
Centerline to top (in)	I	17.00	17.00	17.00	20.00
Clearance for plate changing (in)	I ₁	8.00	8.00	8.00	10.00
Diameter hub at point of welding (in)	O	2.47	3.59	4.62	6.78
Size of "NPT" drain plugs (in) ⁽²⁾	P	0.50	0.50	1.00	0.75
Orifice plate thickness (in) ⁽³⁾		0.12	0.12	0.12	0.12
Minimum clearance for clamping bar removal (in)	W	13.00	13.00	15.00	20.00

(1) Consult factory for other trim options for severe service and other code requirements, including low-temperature, high H₂S, high CO₂, ISO 5167, PED, Daniel "AASG" and special applications.

(2) Flanged process connections available.

(3) Standard plate thickness provided. Consult factory for additional plate thickness options.

Daniel Senior Orifice Fitting with Flangnek Ring Joint 2-in to 16-in ANSI 1500 and 2-in to 12-in ANSI 2500

The dimensional diagrams in Figure 12 below indicate the component measurements provided in the charts on this page. All weights and dimensions are based on standard material offerings. The certified approval drawing will include the actual weights and dimensions.

Figure 12: Daniel Senior Orifice Fitting with Flangnek™ Ring Joint available in 2-in to 16-in ANSI 1500 and 2-in to 12-in ANSI 2500

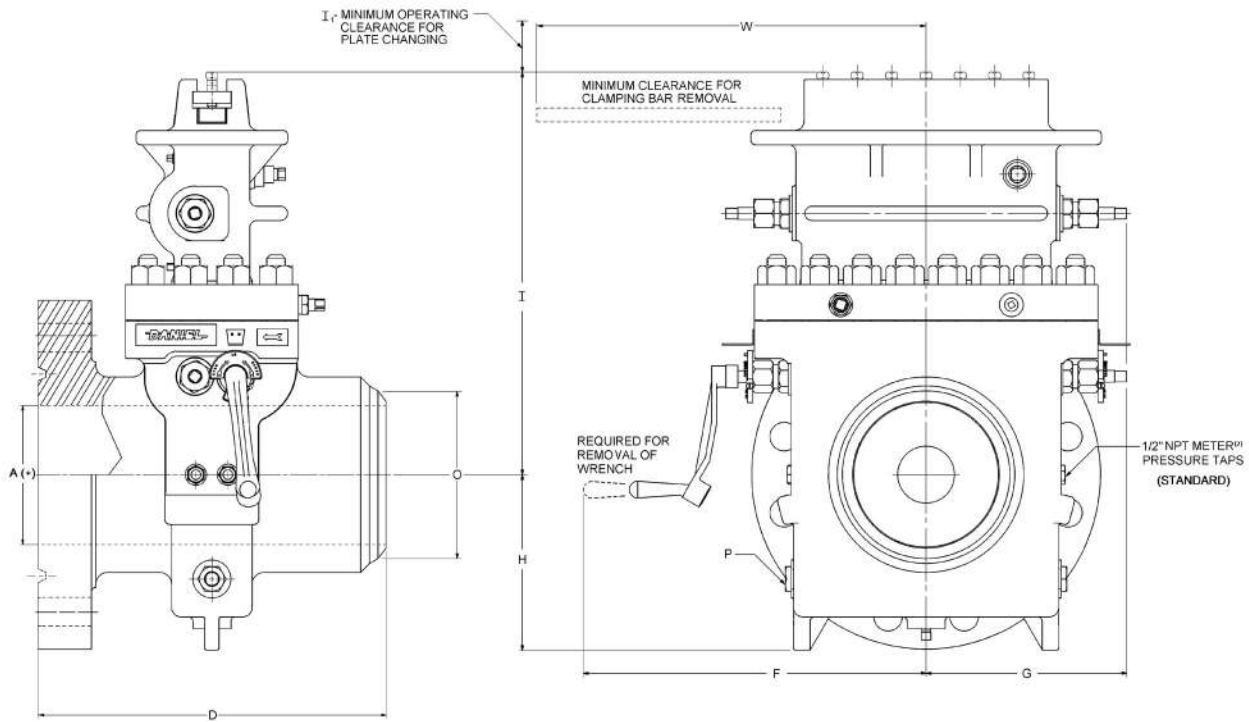

(*) 'A' represents the internal line bore size of the fitting. Consult factory for the complete range of available bore sizes.

ANSI 1500 Daniel Flangnek-Ring Joint 2-in to 16-in (use PTFE Seal ring or SSR only)									
Lines size (in)		2	3	4	6	8	10	12	16
Weight (lb)		205	275	445	710	1,240	1,745	2,805	CF
Standard trim ⁽¹⁾		A	A	A	A	A	A	A	A
Overall face to face dimension (in)	D	14.12	16.12	16.50	21.31	23.50	25.25	27.50	29.44
Operating clearances from center (in)	F	13.00	14.00	16.00	16.00	18.00	19.00	23.00	28.00
Body clearance from center (in)	G	7.00	8.00	10.00	10.00	12.00	13.00	17.00	22.00
Clearance to bottom (in)	H	6.00	6.00	7.00	8.00	10.00	12.00	14.00	17.00
Centerline to top (in)	I	14.00	15.00	17.00	20.00	23.00	26.00	29.00	36.00
Clearance for plate changing (in)	I ₁	6.00	7.00	8.00	10.00	12.00	14.00	16.00	20.00

(1) Consult factory for other trim options for severe service and other code requirements, including low-temperature, high H₂S, high CO₂, ISO 5167, PED, Daniel "AASG" and special applications.

Continued on the next page

Continued from the previous page

ANSI 1500 Daniel Flangnek-Ring Joint 2-in to 16-in (use PTFE Seal ring or SSR only)									
Lines size (in)		2	3	4	6	8	10	12	16
Diameter hub at point of welding (in)	O	2.47	3.59	4.62	6.78	8.78	10.94	12.97	16.25
Size of "NPT" drain plugs (in)⁽²⁾	P	0.50	0.50	0.75	0.75	0.75	0.75	0.75	0.75
Orifice plate thickness (in)⁽³⁾		0.12	0.12	0.12	0.12	0.25	0.25	0.25	0.38
Minimum clearance for clamping bar removal (in)	W	11.00	13.00	16.00	20.00	22.00	26.00	30.00	36.00

- (2) Flanged process connections available.
- (3) Standard plate thickness provided. Consult factory for additional plate thickness options.

ANSI 2500 Daniel Flangnek-Ring Joint 2-in to 12-in(1) (use PTFE Seal ring or SSR only)					
Lines size (in)		2	3	4	6
Weight (lb)		520	575	715	1,195
Standard trim⁽¹⁾		A	A	A	A
Overall face to face dimension (in)	D	17.50	19.50	21.50	25.62
Operating clearances from center (in)	F	16.00	16.00	17.00	18.00
Body clearance from center (in)	G	10.00	10.00	11.00	12.00
Clearance to bottom (in)	H	7.00	7.00	8.00	12.00
Centerline to top (in)	I	17.00	17.00	17.00	20.00
Clearance for plate changing (in)	I₁	8.00	8.00	8.00	10.00
Diameter hub at point of welding (in)	O	2.47	3.59	4.62	6.78
Size of "NPT" drain plugs (in)⁽²⁾	P	0.50	0.50	1.00	0.75
Orifice plate thickness (in)⁽³⁾		0.12	0.12	0.12	0.12
Minimum clearance for clamping bar removal (in)	W	13.00	13.00	15.00	20.00

- (1) Consult factory for other trim options for severe service and other code requirements, including low-temperature, high H₂S, high CO₂, ISO 5167, PED, Daniel "AASG" and special applications.
- (2) Flanged process connections available.
- (3) Standard plate thickness provided. Consult factory for additional plate thickness options.

Daniel Senior Orifice Fitting with Flanged Raised Face 16-in ANSI 150 to 300 and 2-in to 16-in ANSI 600 to 900

The dimensional diagrams in [Figure 13](#) below indicate the component measurements provided in the charts on this page. All weights and dimensions are based on standard material offerings. The certified approval drawing will include the actual weights and dimensions.

Figure 13: Daniel Senior Orifice Fitting with Flanged Raised Face available in 16-in ANSI 150 to 300 and 2-in to 16-in ANSI 600 to 900

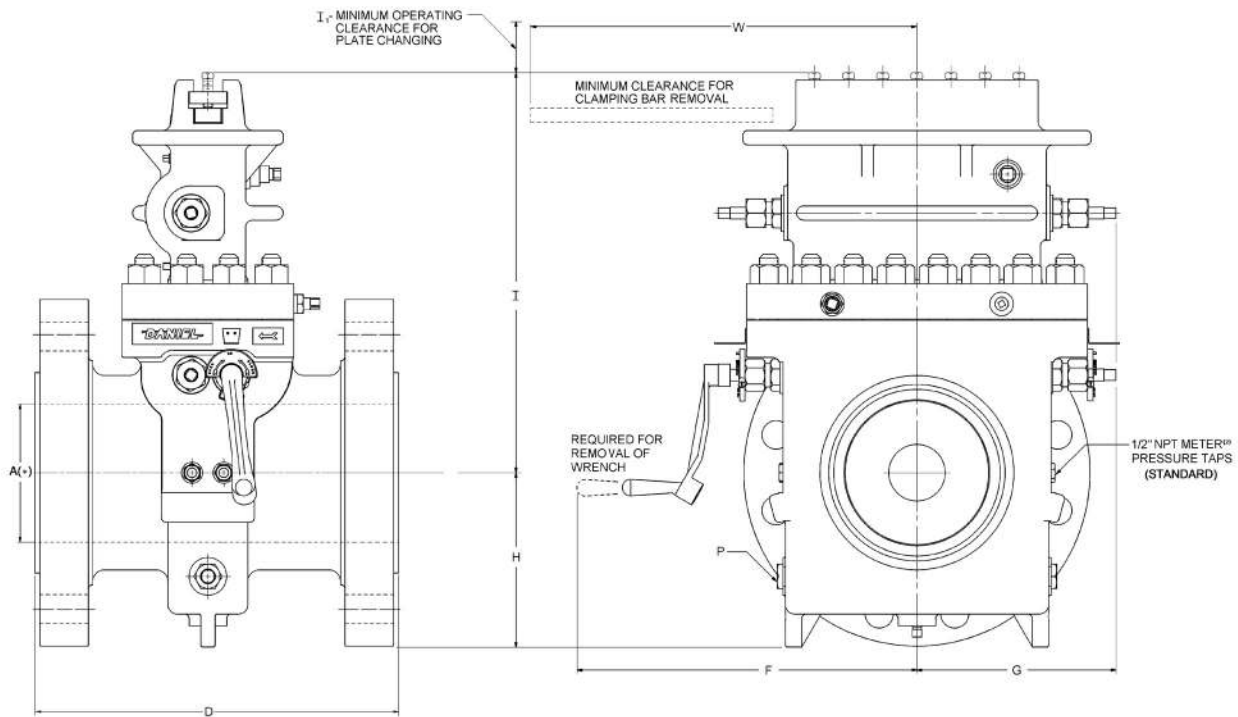

(*) 'A' represents the internal line bore size of the fitting. Consult factory for the complete range of available bore sizes.

ANSI 150 Daniel Flanged-Raised Face 16-in	
Lines size (in)	16
Weight (lb)	1,350
Standard trim ⁽¹⁾	A
Overall face to face dimension (in)	D 16.00
Operating clearance from center (in)	F 24.00
Body clearance from center (in)	G 18.00
Clearance to bottom (in)	H 12.00
Centerline to top (in)	I 36.00
Clearance for plate changing (in)	I ₁ 20.00
Size of "NPT" drain plugs ⁽²⁾ (in)	P 0.75
Orifice plate thickness (in) ⁽³⁾	0.38
Minimum clearance for clamping bar removal (in)	W 34.00

(1) Consult factory for other trim options for severe service and other code requirements, including low-temperature, high H₂S, high CO₂, ISO 5167, PED, Daniel "AASG" and special applications.

(2) Flanged process connections available.

(3) Standard plate thickness provided. Consult factory for additional plate thickness options.

ANSI 300 Daniel Flanged-Raised Face 16-in	
Lines size (in)	16
Weight (lb)	1,810
Standard trim⁽¹⁾	A
Overall face to face dimension (in)	D 17.75
Operating clearance from center (in)	F 24.00
Body clearance from center (in)	G 18.00
Clearance to bottom (in)	H 13.00
Centerline to top (in)	I 36.00
Clearance for plate changing (in)	I₁ 20.00
Size of "NPT" drain plugs⁽²⁾ (in)	P 0.75
Orifice plate thickness (in)⁽³⁾	0.38
Minimum clearance for clamping bar removal (in)	W 34.00

- (1) Consult factory for other trim options for severe service and other code requirements, including low-temperature, high H₂S, high CO₂, ISO 5167, PED, Daniel "AASG" and special applications.
- (2) Flanged process connections available.
- (3) Standard plate thickness provided. Consult factory for additional plate thickness options.

ANSI 600 Daniel Flanged-Raised Face 2-in to 16-in									
Lines size (in)		2	3	4	6	8	10	12	16
Weight (lb)		115	175	300	480	710	920	1,430	2,680
Standard trim⁽¹⁾		NACE	NACE	NACE	NACE	NACE	A	A	A
Overall face to face dimension (in)	D	13.75	17.50	17.50	20.88	23.00	23.50	25.26	21.62
Operating clearances from center (in)	F	13.00	14.00	15.00	16.00	17.00	18.00	20.00	24.00
Body clearance from center (in)	G	7.00	8.00	9.00	10.00	11.00	12.00	14.00	18.00
Clearance to bottom (in)	H	6.00	6.00	7.00	8.00	9.00	10.00	12.00	14.00
Centerline to top (in)	I	14.00	15.00	16.00	19.00	22.00	25.00	29.00	36.00
Clearance for plate changing (in)	I₁	6.00	6.00	7.00	8.00	11.00	13.00	15.00	20.00
Size of "NPT" drain plugs (in)⁽²⁾	P	0.50	0.50	0.75	1.00	1.00	1.00	0.75	0.75
Orifice plate thickness (in)⁽³⁾		0.12	0.12	0.12	0.25	0.25	0.25	0.25	0.38
Minimum clearance for clamping bar removal (in)	W	9.00	11.00	13.00	16.00	19.00	22.00	26.00	36.00

- (1) Consult factory for other trim options for severe service and other code requirements, including low-temperature, high H₂S, high CO₂, ISO 5167, PED, Daniel "AASG" and special applications.
- (2) Flanged process connections available.
- (3) Standard plate thickness provided. Consult factory for additional plate thickness options.

ANSI 900 Daniel Flanged-Raised Face 2-in to 16-in (use PTFE Seal Ring or SSR only)									
Lines size (in)		2	3	4	6	8	10	12	16
Weight (lb)		230	245	355	600	1,265	1,800	2,260	4,693
Standard trim⁽¹⁾		A	A	A	A	A	A	A	A
Overall face to face dimension (in)	D	14.00	14.00	15.00	16.628	18.38	21.88	23.38	25.38
Operating clearances from center (in)	F	14.00	14.00	15.00	16.00	17.00	19.00	21.00	24.00
Body clearance from center (in)	G	7.00	8.00	9.00	10.00	11.00	13.00	15.00	18.00
Clearance to bottom (in)	H	6.00	6.00	7.00	8.00	10.00	12.00	12.00	14.00
Centerline to top (in)	I	14.00	15.00	16.00	19.00	22.00	25.00	29.00	37.00
Clearance for plate changing (in)	I₁	6.00	7.00	8.00	10.00	12.00	14.00	16.00	20.00
Size of "NPT" drain plugs (in)⁽²⁾	P	0.50	0.50	0.75	0.75	0.75	0.75	0.75	0.75
Orifice plate thickness (in)⁽³⁾		0.12	0.12	0.12	0.12	0.25	0.25	0.25	0.25
Minimum clearance for clamping bar removal (in)	W	11.00	11.00	13.00	16.00	20.00	26.00	28.00	36.00

- (1) Consult factory for other trim options for severe service and other code requirements, including low-temperature, high H₂S, high CO₂, ISO 5167, PED, Daniel "AASG" and special applications.
- (2) Flanged process connections available.
- (3) Standard plate thickness provided. Consult factory for additional plate thickness options.

Daniel Senior Orifice Fitting with Flanged Ring Joint 2-in to 16-in ANSI 600 to ANSI 900

The dimensional diagrams in Figure 14 below indicate the component measurements provided in the charts on this page. All weights and dimensions are based on standard material offerings. The certified approval drawing will include the actual weights and dimensions.

Figure 14: Daniel Senior Orifice Fitting with Flanged Ring Joint available in 2-in to 16-in ANSI 600 to ANSI 900

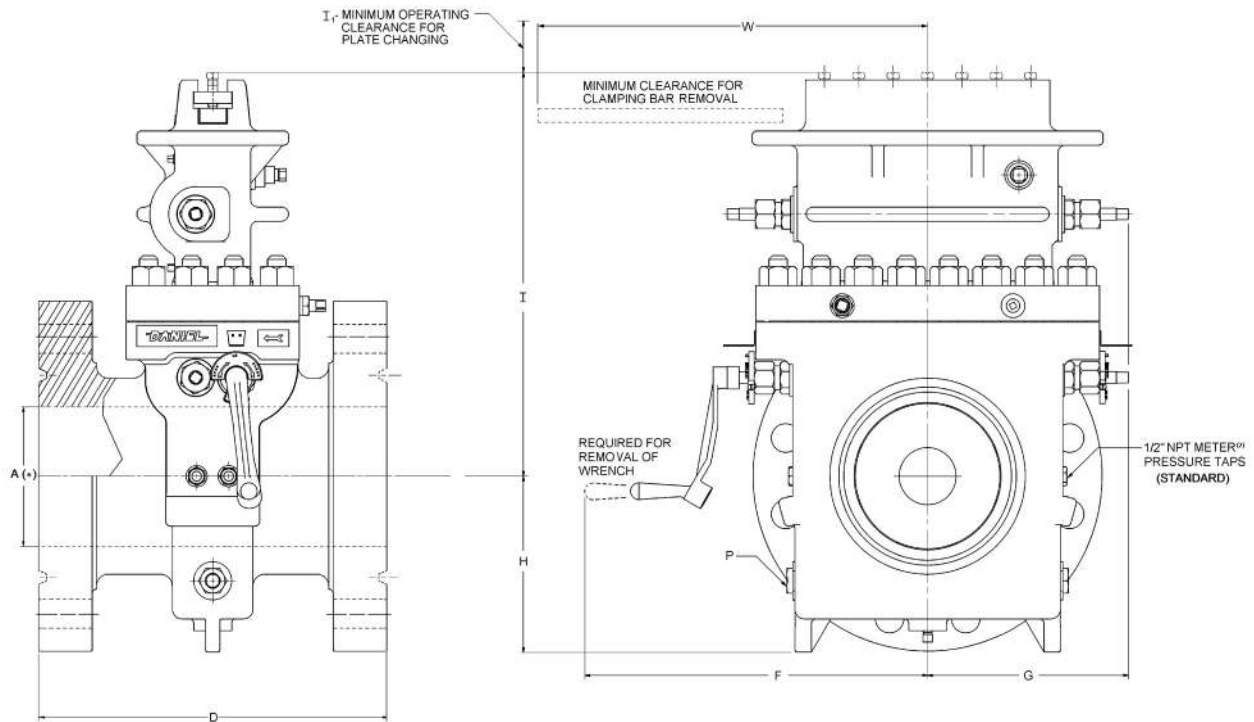

(*) 'A' represents the internal line bore size of the fitting. Consult factory for the complete range of available bore sizes.

ANSI 600 Daniel Flanged-Ring Joint 2-in to 16-in									
Lines size (in)		2	3	4	6	8	10	12	16
Weight (lb)		115	175	300	480	710	920	1,430	2,315
Standard trim ⁽¹⁾		NACE	NACE	NACE	NACE	NACE	NACE	A	A
Overall face to face dimension (in)	D	13.94	17.69	17.69	21.06	23.19	23.69	25.44	21.75
Operating clearances from center (in)	F	13.00	14.00	15.00	16.00	17.00	18.00	20.00	24.00
Body clearance from center (in)	G	7.00	8.00	9.00	10.00	11.00	12.00	14.00	18.00
Clearance to bottom (in)	H	4.00	5.00	6.00	7.00	9.00	10.00	12.00	14.00
Centerline to top (in)	I	14.00	15.00	16.00	19.00	22.00	25.00	29.00	36.00
Clearance for plate changing (in)	I ₁	6.00	7.00	8.00	10.00	12.00	13.13	15.00	20.00

(1) Consult factory for other trim options for severe service and other code requirements, including low-temperature, high H₂S, high CO₂, ISO 5167, PED, Daniel "AASG" and special applications.

Continued on the next page

Continued from the previous page

ANSI 600 Daniel Flanged-Ring Joint 2-in to 16-in									
Lines size (in)		2	3	4	6	8	10	12	16
Size of "NPT" drain plugs (in) ⁽²⁾	P	0.50	0.50	0.75	1.00	1.00	1.00	1.00	0.75 ⁽³⁾
Orifice plate thickness (in) ⁽⁴⁾		0.12	0.12	0.12	0.12	0.25	0.25	0.25	0.38
Minimum clearance for clamping bar removal (in)	W	9.00	11.00	13.00	16.00	19.00	22.00	26.00	36.00

- (2) The flange-by-flange (F x F) configuration of the 2-in to 12-in Senior Orifice Fittings has changed on ANSI 600 models only. The flange-by-flange configuration has been replaced with a raised-face or ring-type-joint Flangnek (RFFN or RTJ FN) configuration featuring a flange welded to the upstream side (inlet) of the Flangnek fitting. This means the face-to-face dimensions are longer than previous versions and will not retrofit into the void of a F x F Senior Orifice Fitting purchased prior to August 2012. To replace discontinued F x F models, existing piping must be modified to accommodate the added length.
- (3) Flanged process connections available.
- (4) Standard plate thickness provided. Consult factory for additional plate thickness options.

ANSI 900 Daniel Flanged-Ring Joint 2-in to 16-in (use PTFE Seal ring or SSR only)									
Lines size (in)		2	3	4	6	8	10	12	16
Weight (lb)		230	245	355	600	1,265	1,800	2,260	4,781
Standard trim ⁽¹⁾		A	A	A	A	A	A	A	A
Overall face to face dimension (in)	D	14.12	14.12	15.12	16.75	18.50	22.00	23.50	26.00
Operating clearances from center (in)	F	13.00	14.00	15.00	16.00	17.00	19.00	21.00	24.00
Body clearance from center (in)	G	7.00	8.00	9.00	10.00	11.00	13.00	15.00	18.00
Clearance to bottom (in)	H	6.00	6.00	7.00	8.00	10.00	12.00	12.00	14.00
Centerline to top (in)	I	14.00	15.00	16.00	19.00	22.00	25.00	29.00	37.00
Clearance for plate changing (in)	I ₁	6.00	7.00	8.00	10.00	12.00	14.00	16.00	20.00
Size of "NPT" drain plugs (in) ⁽²⁾	P	0.50	0.50	0.75	0.75	0.75	0.75	0.75	0.75
Orifice plate thickness (in) ⁽³⁾		0.12	0.12	0.12	0.12	0.25	0.25	0.25	0.38
Minimum clearance for clamping bar removal (in)	W	11.00	11.00	13.00	16.00	20.00	26.00	28.00	36.00

- (1) Consult factory for other trim options for severe service and other code requirements, including low-temperature, high H₂S, high CO₂, ISO 5167, PED, Daniel "AASG" and special applications.
- (2) Flanged process connections available.
- (3) Standard plate thickness provided. Consult factory for additional plate thickness options.

Daniel Senior Orifice Fitting Flanged Raised Face 2-in to 16-in ANSI 1500 and 2-in to 12-in ANSI 2500

The dimensional diagrams in [Figure 15](#) below indicate the component measurements provided in the charts on this page. All weights and dimensions are based on standard material offerings. The certified approval drawing will include the actual weights and dimensions.

Figure 15: Daniel Senior Orifice Fitting with Flanged Raised Face⁽⁵⁾ available in 2-in to 16-in ANSI 1500 and 2-in to 12-in ANSI 2500

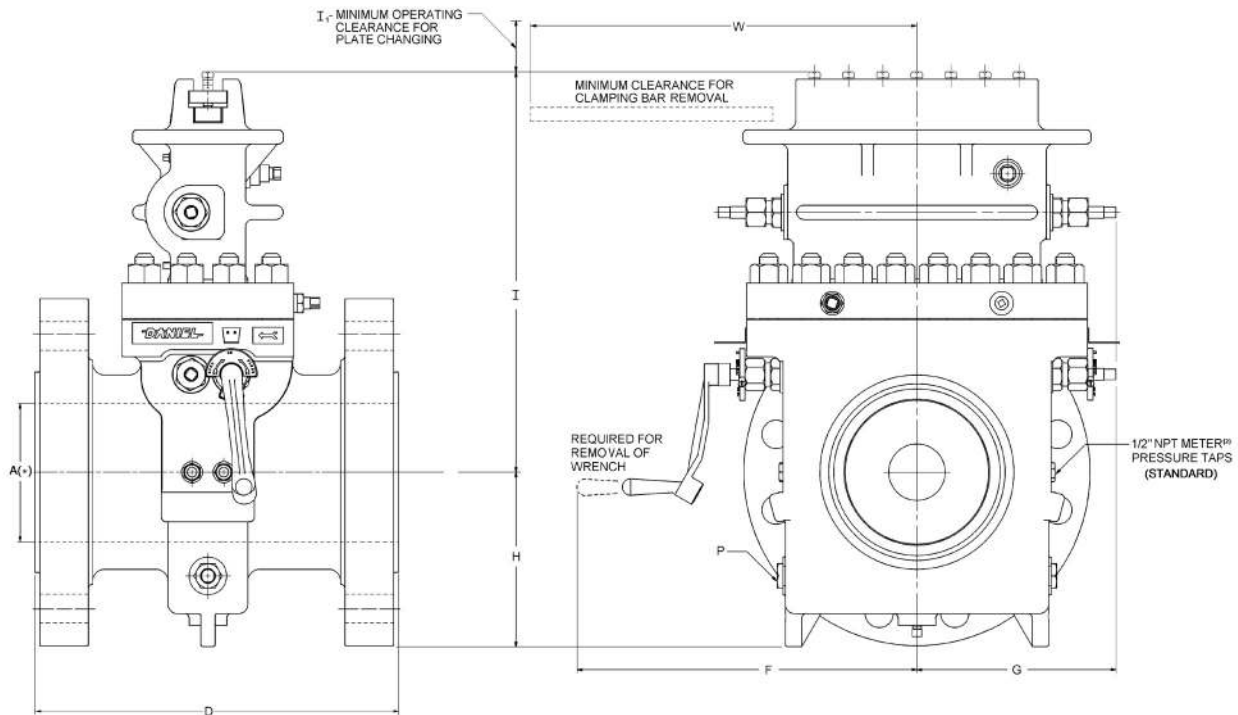

(*) 'A' represents the internal line bore size of the fitting. Consult factory for the complete range of available bore sizes.

ANSI 1500 Daniel Flanged-Raised Face 2-in to 16-in (use PTFE Seal ring or SSR only)									
Lines size (in)		2	3	4	6	8	10	12	16
Weight (lb)		230	275	520	875	1,500	2,180	3,470	CF
Standard trim ⁽¹⁾		A	A	A	A	A	A	A	A
Overall face to face dimension (in)	D	14.00	16.00	16.38	21.06	23.12	24.88	26.88	33.75
Operating clearances from center (in)	F	13.00	14.00	16.00	16.00	18.00	19.00	23.00	28.00
Body clearance from center (in)	G	7.00	8.00	10.00	10.00	12.00	13.00	17.00	22.00
Clearance to bottom (in)	H	6.00	6.00	7.00	8.00	10.00	12.00	14.00	17.00

(1) Consult factory for other trim options for severe service and other code requirements, including low-temperature, high H₂S, high CO₂, ISO 5167, PED, Daniel "AASG" and special applications.

Continued on the next page

(5) 4-in to 6-in ANSI 2500 Senior fittings are available in Flangenek configurations only. A flange may be welded on to fittings in all other line sizes and pressure ratings to create a flanged version.

Continued from the previous page

ANSI 1500 Daniel Flanged-Raised Face 2-in to 16-in (use PTFE Seal ring or SSR only)									
Lines size (in)		2	3	4	6	8	10	12	16
Centerline to top (in)	I	14.00	15.00	17.00	20.00	23.00	26.00	29.00	36.00
Clearance for plate changing (in)	I ₁	6.00	7.00	8.00	10.00	12.00	14.00	16.00	20.00
Size of "NPT" drain plugs (in)⁽²⁾	P	0.50	0.50	0.75	0.75	0.75	0.75	0.75	0.75
Orifice plate thickness (in)⁽³⁾		0.12	0.12	0.12	0.12	0.25	0.25	0.25	0.25
Minimum clearance for clamping bar removal (in)	W	11.00	13.00	16.00	20.00	22.00	26.00	30.00	36.00

- (2) Flanged process connections available.
- (3) Standard plate thickness provided. Consult factory for additional plate thickness options.

ANSI 2500 Daniel Flanged-Raised Face 2-in to 12-in (use PTFE Seal ring or SSR only)								
Lines size (in)		2	3	4	6	8	10	12
Weight (lb)		560	660	840	1,520	CF	CF	CF
Standard trim⁽¹⁾		A	A	A	A	A	A	A
Overall face to face dimension (in)	D	17.38	19.25	CF	CF	39.38	45.50	47.00
Operating clearances from center (in)	F	16.00	16.00	17.00	18.00	26.00	27.00	27.00
Body clearance from center (in)	G	10.00	10.00	11.00	12.00	20.00	21.00	21.00
Clearance to bottom (in)	H	7.00	7.00	8.00	12.00	11.00	14.00	15.00
Centerline to top (in)	I	17.00	17.00	17.00	20.00	39.00	41.00	41.00
Clearance for plate changing (in)	I ₁	8.00	8.00	8.00	10.00	20.00	21.00	21.00
Size of "NPT" drain plugs (in)⁽²⁾	P	0.50	0.50	1.00	0.75	0.75	0.75	0.75
Orifice plate thickness (in)⁽³⁾		0.12	0.12	0.12	0.12	0.25	0.25	0.25
Minimum clearance for clamping bar removal (in)	W	13.00	13.00	15.00	20.00	16.00	17.00	17.00

- (1) Consult factory for other trim options for severe service and other code requirements, including low-temperature, high H₂S, high CO₂, ISO 5167, PED, Daniel "AASG" and special applications.
- (2) Flanged process connections available.
- (3) Standard plate thickness provided. Consult factory for additional plate thickness options.

Daniel Senior Orifice Fitting with Flanged Ring Joint 2-in to 16-in ANSI 1500 and 2-in to 12-in ANSI 2500

The dimensional diagrams in Figure 16 below indicate the component measurements provided in the charts on this page. All weights and dimensions are based on standard material offerings. The certified approval drawing will include the actual weights and dimensions.

Figure 16: Daniel Senior Orifice Fitting with Flanged Ring Joint⁽⁶⁾ available in 2-in to 16-in ANSI 1500 and 2-in to 12-in ANSI 2500

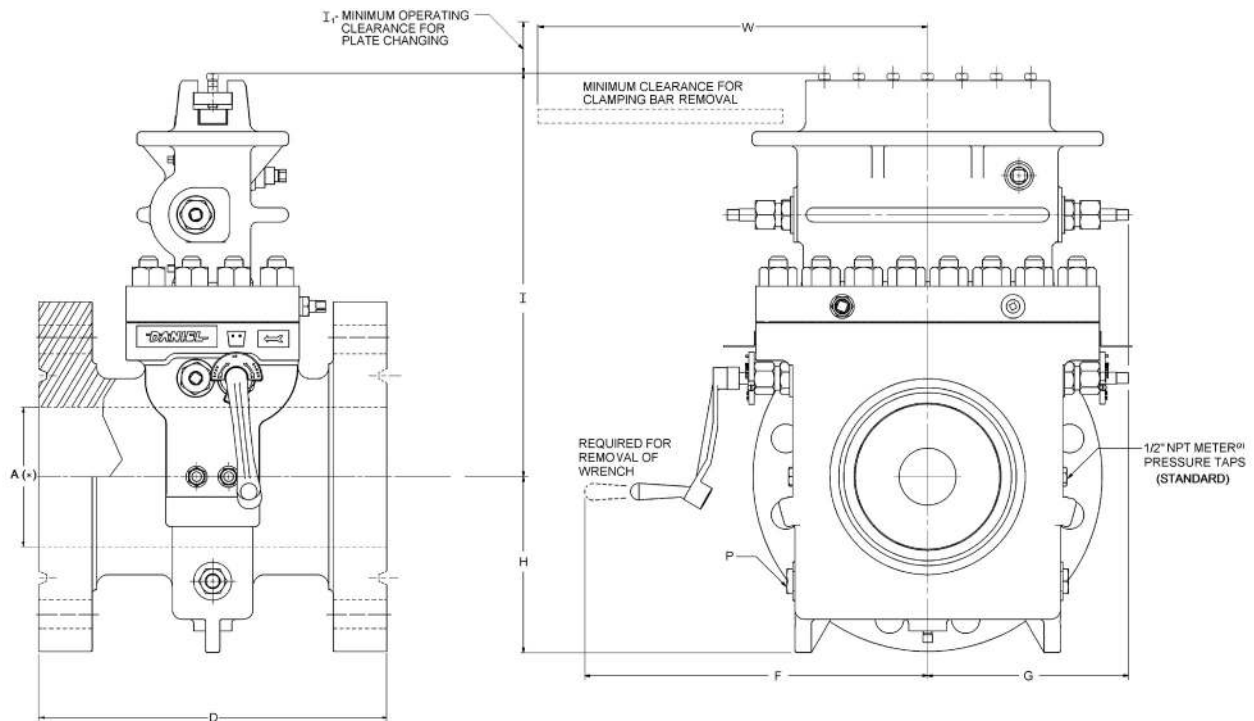

(*) 'A' represents the internal line bore size of the fitting. Consult factory for the complete range of available bore sizes.

ANSI 1500 Daniel Flanged-Ring Joint 2-in to 16-in (use PTFE Seal Ring or SSR only)									
Lines size (in)		2	3	4	6	8	10	12	16
Weight (lb)		230	325	520	875	1,500	2,180	3,470	CF
Standard trim ⁽¹⁾		A	A	A	A	A	A	A	A
Overall face to face dimension (in)	D	14.12	16.12	16.50	21.31	23.50	25.25	27.50	34.62
Operating clearances from center (in)	F	13.00	14.00	16.00	16.00	18.00	19.00	23.00	28.00
Body clearance from center (in)	G	7.00	8.00	10.00	10.00	12.00	13.00	17.00	22.00
Clearance to bottom (in)	H	6.00	6.00	7.00	8.00	10.00	12.00	14.00	17.00

(1) Consult factory for other trim options for severe service and other code requirements, including low-temperature, high H₂S, high CO₂, ISO 5167, PED, Daniel "AASG" and special applications.

Continued on the next page

(6) 4-in to 6-in ANSI 2500 Senior fittings are available in Flangnek configurations only. A flange may be welded on to fittings in all other line sizes and pressure ratings to create a flanged version.

Continued from the previous page

ANSI 1500 Daniel Flanged-Ring Joint 2-in to 16-in (use PTFE Seal Ring or SSR only)									
Lines size (in)		2	3	4	6	8	10	12	16
Centerline to top (in)	I	14.00	15.00	17.00	20.00	23.00	26.00	29.00	36.00
Clearance for plate changing (in)	I₁	6.00	7.00	8.00	10.00	12.00	14.00	16.00	20.00
Size of "NPT" drain plugs (in)⁽²⁾	P	0.50	0.50	0.75	0.75	0.75	0.75	0.75	0.75
Orifice plate thickness (in)⁽³⁾		0.12	0.12	0.12	0.12	0.25	0.25	0.25	0.38
Minimum clearance for clamping bar removal (in)	W	11.00	13.00	16.00	20.00	22.00	26.00	30.00	36.00

- (2) Flanged process connections available.
- (3) Standard plate thickness provided. Consult factory for additional plate thickness options.

ANSI 2500 Daniel Flanged-Ring Joint 2-in to 12-in (use PTFE Seal Ring or SSR only)					
Lines size (in)		2	3	4	6
Weight (lb)		560	660	840	1,520
Standard trim⁽¹⁾		A	A	A	A
Overall face to face dimension (in)	D	17.50	19.50	CF	CF
Operating clearances from center (in)	F	16.00	16.00	17.00	18.00
Body clearance from center (in)	G	10.00	10.00	11.00	12.00
Clearance to bottom (in)	H	7.00	7.00	8.00	12.00
Centerline to top (in)	I	17.00	17.00	17.00	20.00
Clearance for plate changing (in)	I₁	8.00	8.00	8.00	10.00
Size of "NPT" drain plugs (in)⁽²⁾	P	0.50	0.50	1.00	0.75
Orifice plate thickness (in)⁽³⁾		0.12	0.12	0.12	0.12
Minimum clearance for clamping bar removal (in)	W	13.00	13.00	15.00	20.00

- (1) Consult factory for other trim options for severe service and other code requirements, including low-temperature, high H₂S, high CO₂, ISO 5167, PED, Daniel "AASG" and special applications.
- (2) Flanged process connections available.
- (3) Standard plate thickness provided. Consult factory for additional plate thickness options.

January 2022

With over 90 Years of experience, Daniel is the only manufacturer that has the knowledge and experience to engineer and offer superior products that are trusted to provide the most reliable and accurate measurements in the global oil and gas industry.

Contact Us

Email: info@daniel.com

Phone: 713-467-6000



Decades Proven. Field Chosen.™

www.daniel.com

©2022 Daniel Measurement and Control | All Rights Reserved | DAN-SOF-TG-0122